

 **Laifual Drive**  
www.laifual.net

 **Laifual Drive**



**Head office & Factory:**

Address: Ganlin Industrial Zone, Shengzhou, Zhejiang, China

Tel: 86-575-83272870

Fax: 86-575-83272888

E-mail: info@laifual.com

Service: service@laifual.com

**Subsidiary company: Suzhou Changmu drive CO., LTD.**

Address: Kangyang building, Huangdai Town, Xiangcheng District,

Suzhou City, Jiangsu, China

Tel: 86-512-67236762

Fax: 86-575-81388192



 **Laifual Drive**

ZHEJIANG LAIFUAL DRIVE CO., LTD

# Product photos

## LSS SERIES



LSS/LSN/LSG



LSS- I -M



LFS- I



LSD

## LHT SERIES



LHT/LHG- I



LHT/LHG- II



LHT/LHN/LHG- III



LHT/LHN/LHG-IV



LHT/LHG- V



LHD- I



LHD- III

# CONTENTS

<b>Principle of harmonic gear reducer</b>		2
<b>Company presentation</b>		3
	Tooth profile	5
	About grease	6
	Terms and definitions	7
	Wave generator	8
<b>Technical information</b>		9
	Installation procedure	9
	Assembly considerations	11
	Installation precautions	12
	Specification of main bearing	13
	Moment load table	14
<b>LSS series</b>		16
	LSS series	16
	Rated parameter table of LSS/LSN series	17
	Rated parameter table of LSG series	17
	LSS/LSN/LSG-I series	18
	Size chart	19
	LSS/LSN/LSG-II series	20
	Size charts	21
	Rated parameter table of LSD series	22
	LSD-I series	23
	Rated parameter table of LFS series	24
	LFS-I series	25
<b>LHT series</b>		26
	LHT series	26
	Rated parameter table of LHT/LHN series	27
	Rated parameter table of LHG series	27
	LHT/LHG-I Size chart	28
	LHT/LHG-II Size chart	30
	LHT/LHN/LHG-III Size chart	32
	LHT/LHN/LHG-IV Size chart	34
	LHT/LHG-V Size chart	36
	Rated parameter table of LHD series	38
	LHD-I size chart	39
	LHD-III size chart	40
<b>Others</b>		41
	Warranty	41
	Trademark	41
	Certification	42
	Application	43
	Safety precautions	44



# Principle of harmonic gear reducer

## I. Composition of harmonic gear reducer

Harmonic gear reducer has three basic components: a wave generator, a flexspline and a circular spline.

Wave generator: it is made up of a ball bearing and an elliptical cam. The wave generator is usually attached to the input end, the inner ring of the bearing is fixed around the cam causing the outer ring of the bearing to deform into an elliptical shape.

Flexspline: it is an elastic thin-walled component with gear teeth on outer surface. It is usually fitted to output end.

Circular spline: it is a rigid steel ring with internal teeth. It usually has two more teeth than the flexspline, and generally mounted onto a housing.

## II. Principle of harmonic gear reducer

As a reducer, the harmonic gear reducer is often in a status as: the wave generator drives, the circular spline is fixed, the flexspline is output end.

When the wave generator is put inside of the flexspline, the flexspline is forced into an elliptical shape causing the flexspline teeth to engage with the tooth profile of the circular spline along the major axis of the ellipse, with the teeth completely disengaged across the minor axis of the ellipse.

The rotation of the wave generator makes the flexspline deform continuously, the teeth change operating state in the process of engagement and disengagement, thus the motion transmission between wave generator and flexspline is realized.

## III. Characteristics of harmonic gear reducer

1. High accuracy: a good percentage of its teeth are meshed at all times, and are engaged at two zones 180 degrees apart. This means influences of tooth pitch errors and accumulated pitch errors on rotational accuracy are neutralized, which assures high positional and rotational accuracy.
2. High speed reduction ratio: a harmonic gear reducer has high single-stage reduction ratios of 1/30-1/500. Three basic components along same axle without complex structures can provide high reduction ratios.
3. High torque capacity: each tooth is subjected to a negligible amount of force yet provides a high torque capacity because of the way the teeth come into contact with each other and because a good percentage of the teeth in the flexspline are engaged at all times.
4. Small-sized and light weight: while being less the size of conventional gearing mechanisms and less the weight, the harmonic gear reducer provides the same levels of torque and speed reduction ratios as its conventional counterparts enabling machinery and equipment to be made smaller and lighter.
5. Superior efficiency and long life time.
6. Quiet and minimal vibration operation.

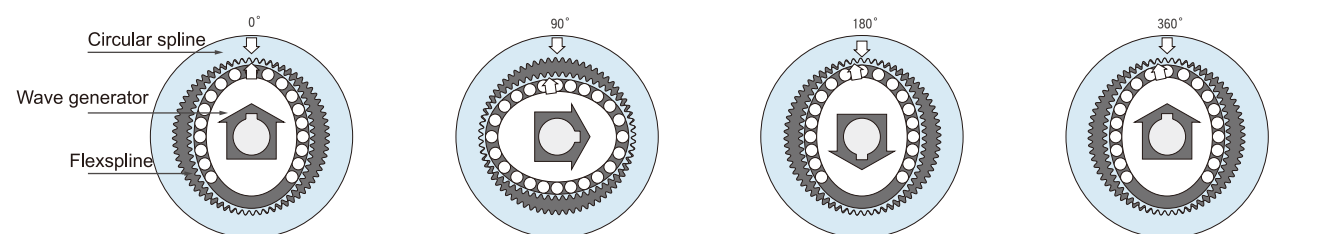

The flexspline is forced into an elliptical shape by the wave generator causing the flexspline teeth to engage with the tooth profile of the circular spline along the major axis of the ellipse, with the teeth completely disengaged across the minor axis of the ellipse

As the wave generator rotates clockwise with the circular spline fixed, the flexspline is subjected to elastic deformation and its tooth engagement position moves turning relative to the circular spline.

As the wave generator rotates 180 degrees clockwise, the flexspline moves counterclockwise by one tooth relative to the circular spline.

For every one full rotation (360 degrees) of the wave generator, the flexspline moves counterclockwise by two teeth relative to the circular spline because the flexspline has two fewer teeth than there are on the circular spline. In general, this movement is treated as output performing.



## Company presentation

Zhejiang Laifual Drive Co., Ltd is a national high-tech enterprise, mainly engaged in research and manufacture of high-precision harmonic reducers and planetary gear reducers. Total factory is 30,000 square meters. About 300 employees, including around 30 R&D Personnel, with more than 10 years experience in research and development.

Laifual uses the world's first class production and inspection equipment. Pay attention to every production details, we have very strict quality control from raw materials to the finished products, to make sure the excellent quality of all products. All products are completely developed by ourselves, Laifual's R&D center is recognized as "High-tech enterprise R&D center in Zhejiang province".

After years of hard working, Laifual has obtained 30 patents in the field of drive area. Including 1 major scientific and technological patent and 29 independent intellectual property rights patents. Laifual was recognized as a national high-tech enterprise, medium-sized enterprise in Zhejiang province, and successfully passed the ISO9001 quality management system certification.

Thanks to years of research and development experience, Laifual has made breakthroughs in many special performance. Our high precision harmonic reducer have the characteristics of low temperature rise, low starting torque, high reliability, big torque, long life time, big speed ratio, small size, etc. Which can be widely used in industrial robots, service robots, medical equipment, high precision automation equipment, etc. And we sincerely provide satisfactory and diversified custom design services for all our valued customers.

Taking professionalization, internationalization as standard, to build Laifual into the most respectable harmonic reducer brand.

# Technical Information

Tooth profile	5
About grease	6
Terms and definitions	7
Wave generator	8
Installation procedure	9
Assembly considerations	11
Installation precautions	12
Specification of main bearing	13
Moment load table	14

## ■ Tooth profile

- Gear toothing capacity increased by 15%
- Reduce gear fatigue pitting contact area
- Temperature rise decreased by 8-10 degrees
- Service time over 15000 hours

### About LS tooth profile

We have made some upgrades based on the traditional theoretical double arc profile. The tooth profile formed by the original two-curve continuous arc curve is optimized as a continuous arc curve with multiple segments of curvature. To ensure that the gears of reducer are properly meshed, while protecting the risk of grease failure after grease is squeezed by reducing relative sliding friction. Based on the  $\delta$  tooth shape, the load capacity is increased by 15%, the temperature rise is reduced by 8-10 degrees, the gear fatigue pitting contact area is reduced by more than 30%, continuous running and service life is over 15000 hours, which improves the overall performance of the harmonic reducer.

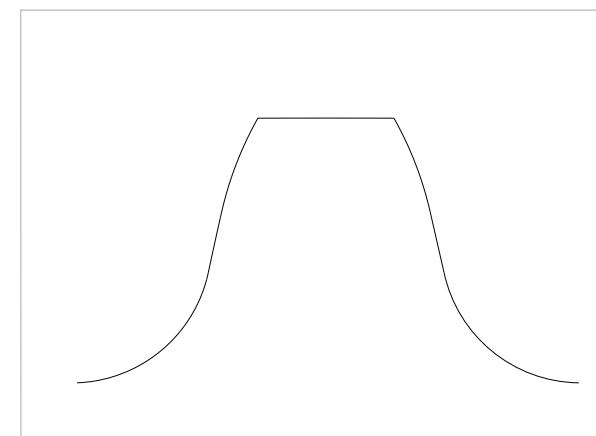
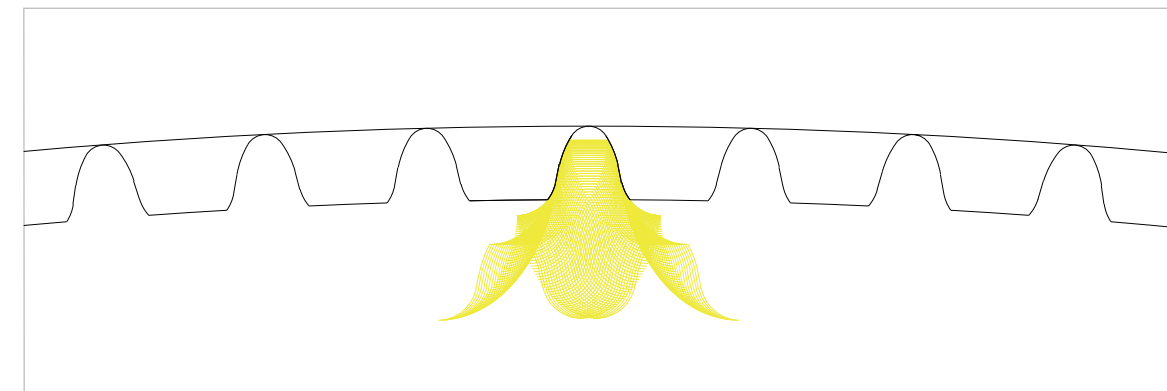

During development, the formation of the soft tooth profile can be determined by the radial displacement of the generator. Different gear reduction ratios can be fitted with various tooth profiles. And the mesh backlash can be conveniently adjusted according to actual conditions. Keep the reducer in the best working condition.

# About grease

## Special grease developed for laifual drive

### Laifual's LF-I grease

Compare with the common greases on the market, Laifual's grease has high efficiency and durable.

### Laifual's LF-II grease

Excellent lubrication when the wave generator is rotated by extruding additives to liquefy.

## Grease characteristics

Model	Color	Operating temperature	Working ambient temperature	Durability	Grease leakage
LF-I	YELLOW	0°C~+40°C	-20°C~+100°C	○	◎
LF-II	GREEN	0°C~+40°C	-20°C~+100°C	○	◎

○ Applicable ◎ Superior

## A suitable grease for different models

Greases for reduction ratio more than 50

Model	Reduction ratio	11	14	17	20	25	32	40
	Grease	LF-I	—	—	—	○	○	○
LF-II		○	○	○	□	□	□	□

○ Standard grease □ Quasi-standard grease

## Seal size description

Series	Model	Circular spline		Flexspline	
		Seal size	Slot size	Seal size	Slot size
LHT-I	14	37 * 1	Φ37 <sup>0</sup> <sub>-0.1</sub> * Φ39.6 <sup>+0.1</sup> <sub>0</sub> * 0.75 <sup>+0.1</sup> <sub>0</sub>	53 * 1.5	Φ53 <sup>0</sup> <sub>-0.1</sub> * Φ56.8 <sup>+0.1</sup> <sub>0</sub> * 1.15 <sup>+0.1</sup> <sub>0</sub>
	17	46.5 * 1	Φ46.5 <sup>0</sup> <sub>-0.1</sub> * Φ49.1 <sup>+0.1</sup> <sub>0</sub> * 0.75 <sup>+0.1</sup> <sub>0</sub>	64 * 1	Φ64 <sup>0</sup> <sub>-0.1</sub> * Φ66.6 <sup>+0.1</sup> <sub>0</sub> * 0.75 <sup>+0.1</sup> <sub>0</sub>
	20	55 * 1	Φ55 <sup>0</sup> <sub>-0.1</sub> * Φ57.6 <sup>+0.1</sup> <sub>0</sub> * 0.75 <sup>+0.1</sup> <sub>0</sub>	73 * 1.5	Φ73 <sup>0</sup> <sub>-0.1</sub> * Φ76.8 <sup>+0.1</sup> <sub>0</sub> * 1.15 <sup>+0.1</sup> <sub>0</sub>
LHT-II	25	68 * 1	Φ68 <sup>0</sup> <sub>-0.1</sub> * Φ70.6 <sup>+0.1</sup> <sub>0</sub> * 0.75 <sup>+0.1</sup> <sub>0</sub>	90 * 1.5	Φ90 <sup>0</sup> <sub>-0.1</sub> * Φ94.2 <sup>+0.1</sup> <sub>0</sub> * 1.15 <sup>+0.1</sup> <sub>0</sub>
	32	88 * 1.5	Φ88 <sup>0</sup> <sub>-0.1</sub> * Φ92 <sup>+0.1</sup> <sub>0</sub> * 1.15 <sup>+0.1</sup> <sub>0</sub>	119 * 1.5	Φ119 <sup>0</sup> <sub>-0.1</sub> * Φ123.1 <sup>+0.1</sup> <sub>0</sub> * 1.15 <sup>+0.1</sup> <sub>0</sub>

# Terms and definitions

## Starting torque

It is the minimum torque value applied to the input end at which the harmonic reducer first starts to rotate with no load.

## Backlash

The clearance between flexspline tooth profile and circular spline tooth profile.

## Rated torque

It indicates allowable continuous output torque at rated input speed.

## Permissible peak torque at start and stop

It's the maximum torque as a result of the moment of inertia of the output load during acceleration and deceleration.

## Permissible maximum value for average load torque

It's the maximum torque when the harmonic reducer keeps continuous operation.

## Permissible maximum momentary torque

It is the momentary peak torque the harmonic reducer may be subjected to the event of a collision or emergency stop.

## Permissible maximum input rotational speed

Don't exceed the permissible rating.

## Permissible average input rotational speed

It's the average value of input speed.



# Wave generator

The wave generator includes a structure of a European-style coupling with a self-aligning structure and an integrated type without an automatic self-aligning structure, and varies depending on the series. For details, please refer to the outline drawing of each series.

• Basic structure and shape of wave generator shown as below:

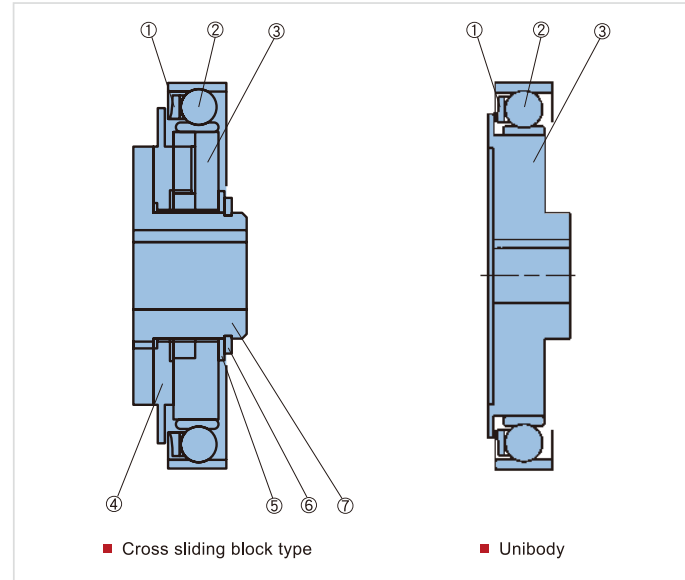

• Structure of cross sliding block type-Using European coupling structure

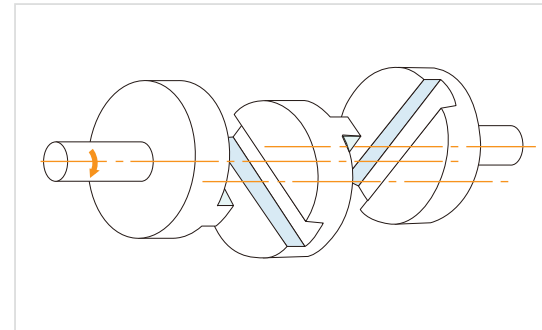

- ① Holder of flexible bearing
- ② Flexible bearing
- ③ Wave generator
- ④ Cross sliding block
- ⑤ Gasket
- ⑥ Ring-shield
- ⑦ Power input shaft

## Axial force and axial fixation of wave generator

The axial force on wave generator begins to work due to elastic deformation of flexspline.  
 When used as a reducer, the axial force moves towards to the inside of the flexspline.  
 When used as a speed increaser, the axial force's movement is opposite to the direction of the deceleration.  
 The design of prevent axial force of wave generator shall be adopted under any conditions of usage.  
 \*Please make sure to consult with the authorized distributor when setting the stop screw and fixing it to the input axial on the wave generator.

• Axial force direction of the wave generator

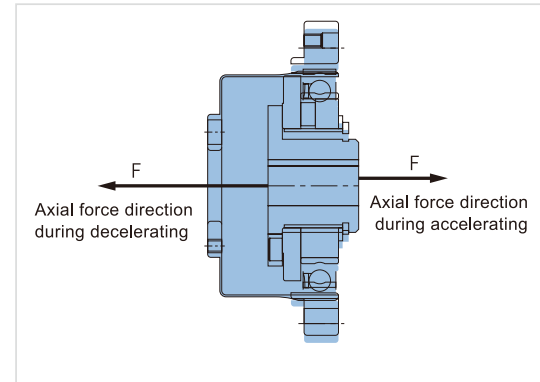

## Maximum aperture size of the unibody wave generator

The standard aperture of the wave generator has shown in the outline-drawing, the alteration can be made within maximum size range shown in the table.  
 We suggest to use GB standard for keyway size. The key's effective length dimension should be designed to fully withstand the value of the transmitted torque.

• Wave generator aperture

Model	11	14	17	20	25	32	40
Standard size (H7)	6	6	8	8	14	14	14
Minimum size	3	3	4	5	6	6	10
Maximum size	8	17	20	23	28	36	42

The aperture of the wave generator can be customized according to customer requirements. Please contact with the authorized distributor in case of any changes in the table.

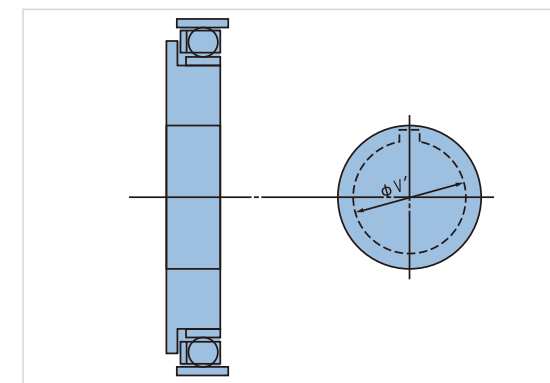

# Installation procedure

## Installation of LSS series

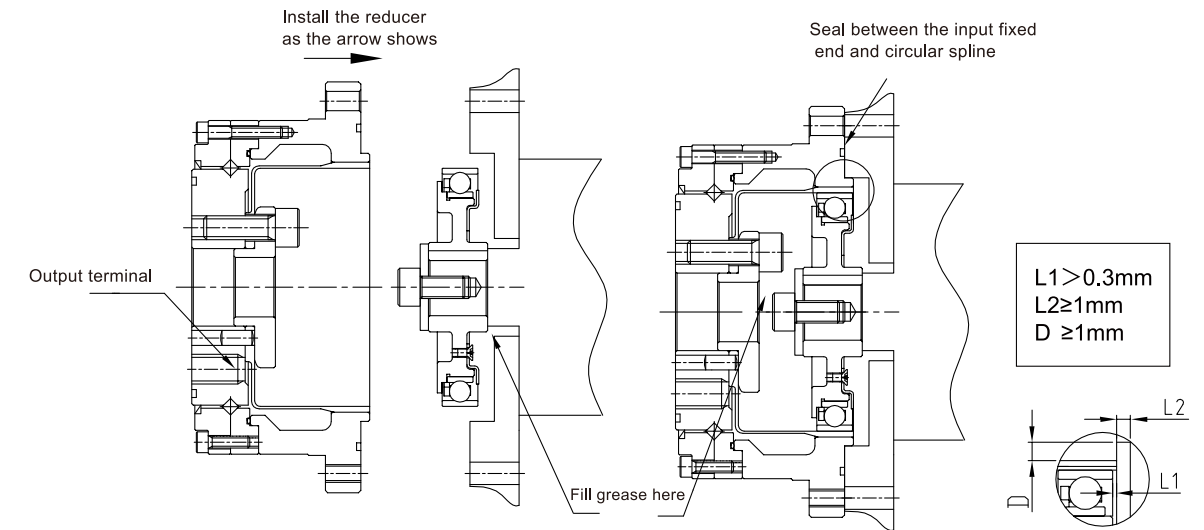

## The first method of installation for LHT-I/II Series

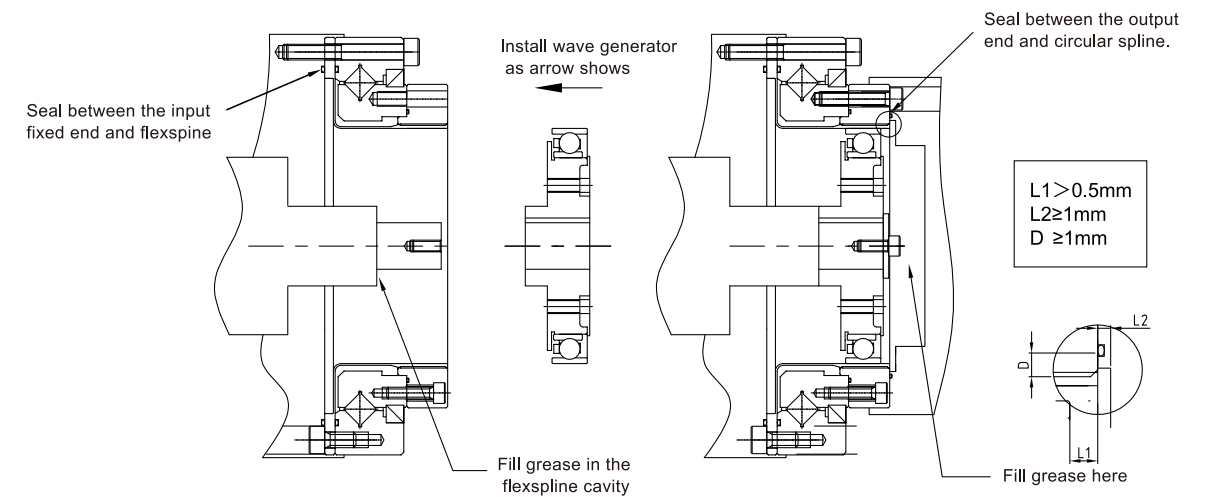

## The second method of installation for LHT-I/II series

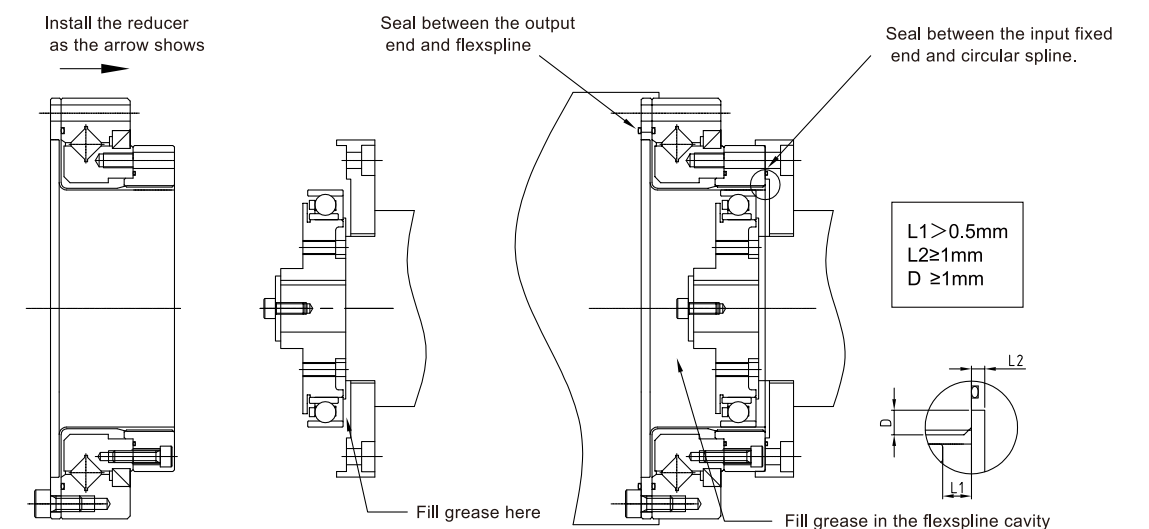

# Installation procedure

## The connecting and fixing method of wave generator

1. Input shaft has a shaft shoulder, it can be connected with wave generator directly. As shown in the figure.

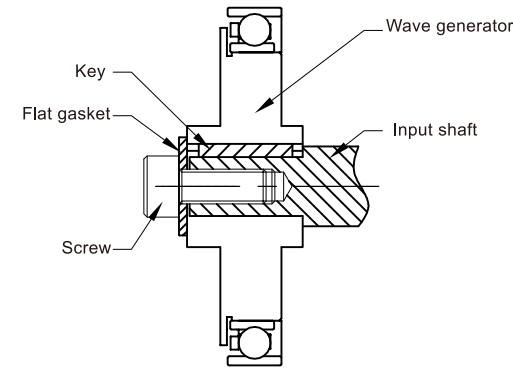

2. Input shaft has a shaft shoulder, but it's too long. You can add a space ring on the shaft (the parallelism of space ring should be within 0.01mm), then connect and fix with the wave generator. As shown in the figure.

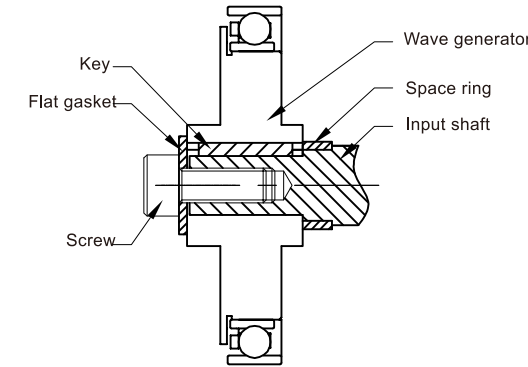

3. Input shaft has no shaft shoulder. Fix a connection gasket on the wave generator, then connect and fix with the input shaft. As shown in the figure.

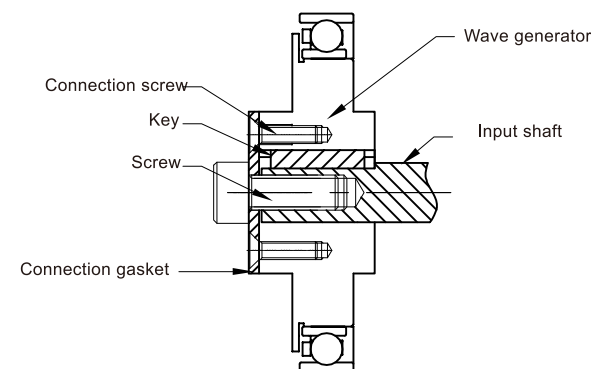

4. This fixing method is suitable for small models, optical axis input. Input shaft inserted into the wave generator, then connect and fix it through the thimble screw on wave generator. As shown in the figure.

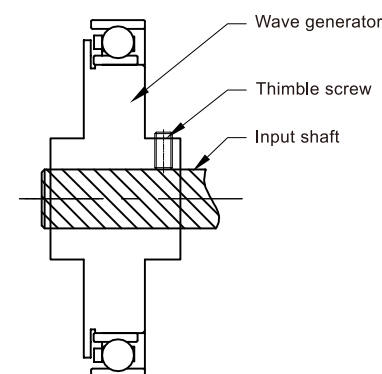

# Assembly considerations

## Assembly procedure

Install the circular spline and flexspline on the device, and then install the wave generator. Otherwise it may cause stuffing damage to the gear teeth or improper eccentric gear mesh. Please pay close attention to it.

### • Correct assembly steps

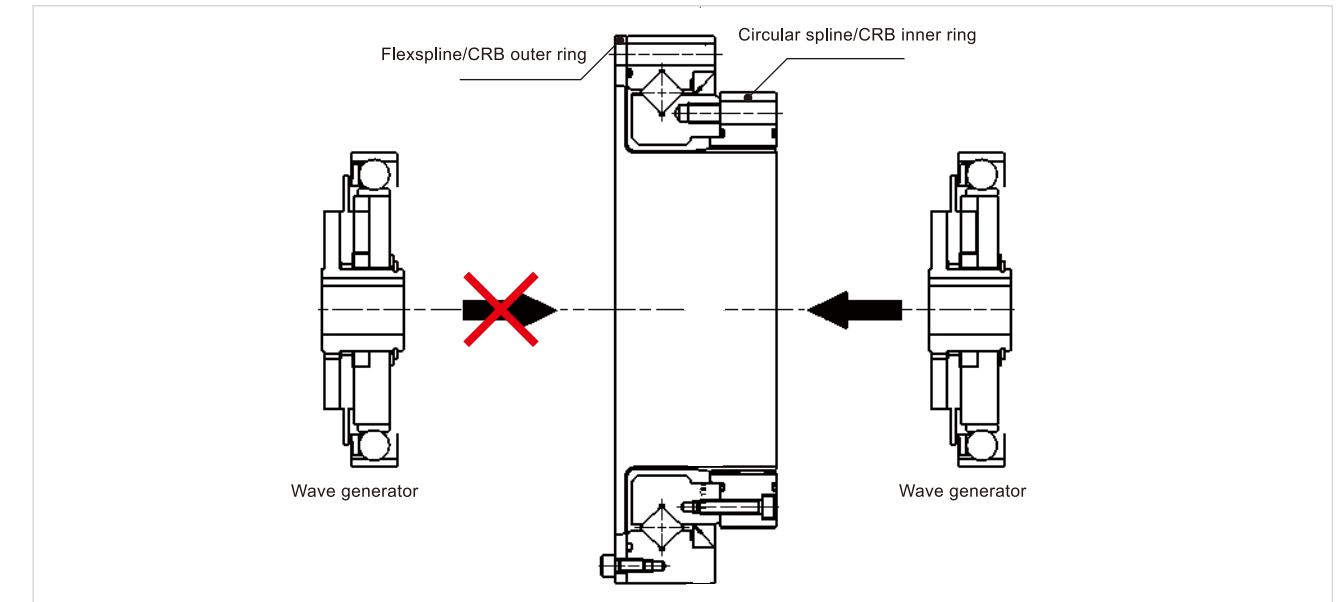

## Precautions on installation

The improper assembly may cause vibration and noise during operation. Please assembly base on the following precautions.

### • Precautions on wave generator

1. Please avoid applying undue force to the bearing on wave generator during assembly. We suggest to rotate the wave generator while inserting, it will ease the process.
2. If the wave generator does not have an oldham coupling, extra care must be given to ensure that concentricity and inclination are within the specified limits.

### • Precautions on circular spline

1. Mounting surfaces need to have adequate flatness, smoothness, and no distortion.
2. Especially in the area of the screw holes, burrs or foreign matter should not be present.
3. Please make sure the chamfering and avoidance machining are performed on the housing assembly, to avoid the interference with the circular spline.
4. The circular spline should be rotatable within the housing. Be sure there is no interference and it does not catch on anything.
5. When mounting the bolt, make sure the bolt hole is correct and aligned. Bolts should rotate freely when tightening and should not have any irregularity due to the bolt hole being misaligned or oblique.
6. Don't tighten the bolts with the specified torque all at once. Tighten the bolts temporarily with about half the specified torque, and then tighten them with the specified torque. Tighten them in an even, crisscross pattern.
7. Avoid pinning the circular spline if possible as it can reduce the rotational precision and smoothness of operation.

### • Precautions on flexspline

1. Mounting surfaces need to have adequate flatness, smoothness, and no distortion.
2. Especially in the area of the screw holes, burrs or foreign matter should not be present.
3. Please make sure the chamfering and avoidance machining are performed on the housing assembly, to avoid the interference with the circular spline.
4. When mounting the bolt, make sure the bolt hole is correct and aligned. Bolts should rotate freely when tightening and should not have any irregularity due to the bolt hole being misaligned or oblique.
5. Don't tighten the bolts with the specified torque all at once. Tighten the bolts temporarily with about half the specified torque, and then tighten them with the specified torque. Tighten them in an even, crisscross pattern.
6. Avoid unilateral meshing and deviation when assembling with circular spline.

### • Rust prevention

The complete assembly unit has no rust prevention on surface.

Please daub anti-rust if needed.

Besides, if an anti-rust product is needed, please contact with the authorized distributor.

# Precautions on installation

## Assembly accuracy of LSS series

To make sure LSS series play its excellent performance when assemble, please make sure to use the following accuracy.

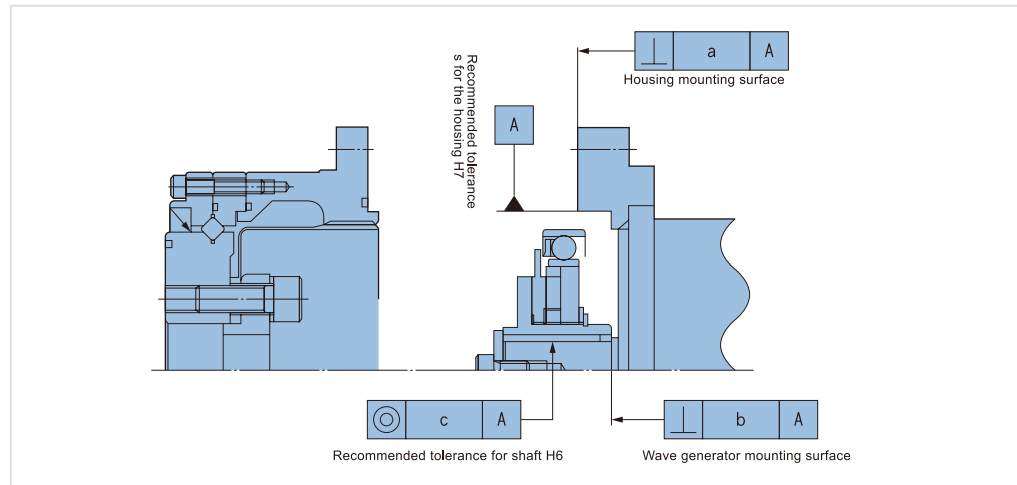

### Recommended accuracy of the assembled housing

unit: mm

Symbol / Model	14	17	20	25	32
a	0.011	0.015	0.017	0.024	0.026
b	0.017 (0.008)	0.020 (0.010)	0.020 (0.010)	0.024 (0.012)	0.024 (0.012)
c	0.030 (0.016)	0.034 (0.018)	0.044 (0.019)	0.047 (0.022)	0.050 (0.022)

\*b,c is the value of the unibody generator (I series) and the cross slider generator (II series).  
The value in ( ) is the value of the unibody generator (I series).

## Assembly accuracy of LHT series

To make sure LHT-I/II series play its excellent performance when assemble, please make sure to use the following accuracy.

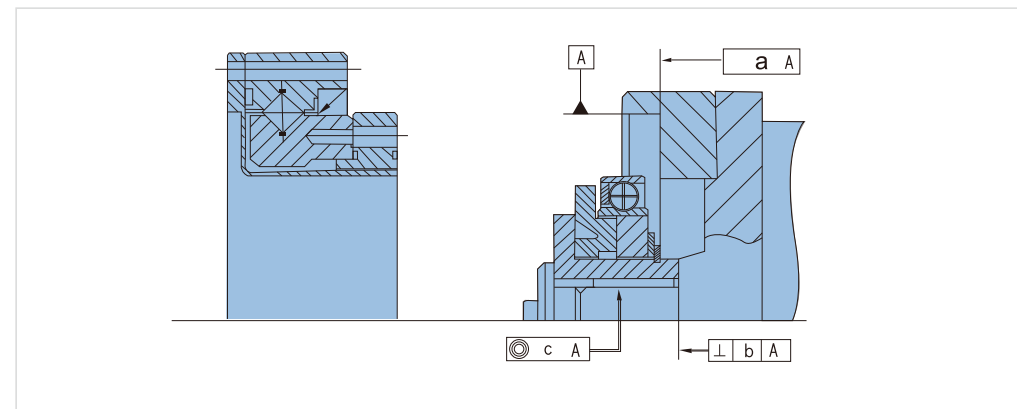

### Recommended accuracy of the assembled housing

unit: mm

Symbol / Model	14	17	20	25	32	40
a	0.011	0.015	0.017	0.024	0.026	0.026
b	0.017 (0.008)	0.020 (0.010)	0.020 (0.010)	0.024 (0.012)	0.024 (0.012)	0.032 (0.012)
c	0.030 (0.016)	0.034 (0.018)	0.044 (0.019)	0.047 (0.022)	0.047 (0.022)	0.050 (0.024)

\*b,c is the value of the unibody generator (I series) and the cross slider generator (II series).  
The value in ( ) is the value of the unibody generator (I series).

# Specification of main bearing

Each product is assembled with precise cross roller bearing for supporting external loading(Output flange).

## Specification of LSS series

Type	Basic rated load				Allowable static moment Mc		Weight kg
	Basic rated dynamic load Cr		Basic rated static load Cr		Nm	kgfm	
	KN	kgf	KN	kgf			
14	4.7	480	6.07	620	41	4.2	0.22
17	5.2	540	7.55	770	64	6.5	0.3
20	5.8	590	9.0	920	91	9.3	0.38
25	9.6	980	15.1	1540	156	16	0.6
32	15	1530	25.1	2550	313	32	1.1

- Basic rated dynamic load refers to static radial load that makes dynamic rated life of bearing reach up to 1 million rotations.
- Basic rated static load refers to static load that exerts a certain level of contact stress(4KN/mm) on the central location between rotor of bearing maximum load and contact part of pathway.
- Allowable static moment refers to the value of the maximum torque exerting on output bearing, within the scope of which, it's workable and the basic performance is possible.

## Starting torque of LSS series

Reduction ratio	Type	11	14	17	20	25	32
50		2.0	4.1	6.1	7.8	15	31
80		1.8	2.8	4	4.9	9.2	19
100		1.5	2.5	3.4	4.3	8	18
120		-	2.3	3.1	3.8	7.3	15
160		-	-	-	3.8	-	-

## Specification of LHT series

Type	Basic rated load				Allowable static moment Mc		Weight kg
	Basic rated dynamic load Cr		Basic rated static load Cr		Nm	kgfm	
	KN	kgf	KN	kgf			
14	5.8	590	8.6	880	74	7.6	0.39
17	10.4	1060	16.3	1670	124	12.6	0.56
20	14.6	1490	22	2250	187	19.1	0.73
25	21.8	2230	35.8	3660	258	26.3	1.23
32	38.2	3900	65.4	6680	580	59.1	2.54
40	43.3	4410	81.6	8330	849	86.6	7.2

- Basic rated dynamic load refers to static radial load that makes dynamic rated life of bearing reach up to 1 million rotations.
- Basic rated static load refers to static load that exerts a certain level of contact stress(4KN/mm) on the central location between rotor of bearing maximum load and contact part of pathway.
- Allowable static moment refers to the value of the maximum torque exerting on output bearing, within the scope of which, it's workable and the basic performance is possible.

## Starting torque of hollow type(LHT-III)

unit: cNm

Reduction ratio	Type	14	17	20	25	32	40
50		8.8	27	36	56	85	136
80		7.5	25	33	50	74	117
100		6.9	24	32	49	72	112
120		6.9	24	31	48	68	110
160		-	-	31	-	-	-

## Starting torque of input axial type(LHT-IV)

unit: cNm

Reduction ratio	Type	14	17	20	25	32	40
50		5.7	9.7	14	22	41	72
80		4.4	7.2	11	15	29	52
100		3.7	6.5	9.9	14	27	47
120		3.4	6.2	9.3	13	24	44
160		-	-	8.6	-	-	-

## Axial input (LHT-IV) timing belt tension torque recommended value

unit: Nm

Generator load torque	Model	14	17	20	25	32
Maximum	LHT-IV	13	19	25	25	52



# Moment load table

Moment load table of LSS(LSG) series

Model	Value	Permissible value at start and stop	Instant permissible value
LSS(LSG)-14	M b di 20Nm	M b peak 40Nm	M b max 80Nm
	F t di 180N	F t peak 320N	F t max 560N
	F a di 180N	F a peak 320N	F a max 560N
LSS(LSG)-17	M b di 30Nm	M b peak 60Nm	M b max 120Nm
	F t di 230N	F t peak 400N	F t max 700N
	F a di 230N	F a peak 400N	F a max 700N
LSS(LSG)-20	M b di 42Nm	M b peak 80Nm	M b max 168Nm
	F t di 270N	F t peak 480N	F t max 830N
	F a di 270N	F a peak 480N	F a max 830N
LSS(LSG)-25	M b di 80Nm	M b peak 160Nm	M b max 313Nm
	F t di 440N	F t peak 770N	F t max 1320N
	F a di 440N	F a peak 770N	F a max 1320N
LSS(LSG)-32	M b di 220Nm	M b peak 440Nm	M b max 890Nm
	F t di 900N	F t peak 1600N	F t max 2700N
	F a di 900N	F a peak 1600N	F a max 2700N

Moment load table of LHT(LHG) series

Model	Value	Permissible value at start and stop	Instant permissible value
LHT(LHG)-14	M b di 41Nm	M b peak 80Nm	M b max 160Nm
	F t di 270N	F t peak 490N	F t max 830N
	F a di 270N	F a peak 490N	F a max 830N
LHT(LHG)-17	M b di 72Nm	M b peak 140Nm	M b max 290Nm
	F t di 400N	F t peak 700N	F t max 1200N
	F a di 400N	F a peak 700N	F a max 1200N
LHT(LHG)-20	M b di 140Nm	M b peak 280Nm	M b max 560m
	F t di 650N	F t peak 1150N	F t max 1980N
	F a di 650N	F a peak 1150N	F a max 1980N
LHT(LHG)-25	M b di 243Nm	M b peak 480Nm	M b max 974Nm
	F t di 900N	F t peak 1600N	F t max 2800N
	F a di 900N	F a peak 1600N	F a max 2800N
LHT(LHG)-32	M b di 460Nm	M b peak 900Nm	M b max 1860Nm
	F t di 1350N	F t peak 2300N	F t max 4000N
	F a di 1350N	F a peak 2300N	F a max 4000N
LHT(LHG)-40	M b di 600Nm	M b peak 1200Nm	M b max 3000Nm
	F t di 2000N	F t peak 3500N	F t max 6000N
	F a di 2000N	F a peak 3500N	F a max 6000N

■ Note: Output load Mb- Bending moment, Ft-radial force, Fa-axial force

Moment load table of LSD series

Model	Value	Permissible value at start and stop	Instant permissible value
LSD-14	M b di 20Nm	M b peak 40Nm	M b max 80Nm
	F t di 180N	F t peak 320N	F t max 560N
	F a di 180N	F a peak 320N	F a max 560N
LSD-17	M b di 30Nm	M b peak 60Nm	M b max 120Nm
	F t di 230N	F t peak 400N	F t max 700N
	F a di 230N	F a peak 400N	F a max 700N
LSD-20	M b di 42Nm	M b peak 80Nm	M b max 168Nm
	F t di 270N	F t peak 480N	F t max 830N
	F a di 270N	F a peak 480N	F a max 830N
LSD-25	M b di 80Nm	M b peak 160Nm	M b max 313Nm
	F t di 440N	F t peak 770N	F t max 1320N
	F a di 440N	F a peak 770N	F a max 1320N
LSD-32	M b di 220Nm	M b peak 440Nm	M b max 890Nm
	F t di 900N	F t peak 1600N	F t max 2700N
	F a di 900N	F a peak 1600N	F a max 2700N

Moment load table of LHD series

Model	Value	Permissible value at start and stop	Instant permissible value
LHD-14	M b di 41Nm	M b peak 80Nm	M b max 160Nm
	F t di 270N	F t peak 490N	F t max 830N
	F a di 270N	F a peak 490N	F a max 830N
LHD-17	M b di 59Nm	M b peak 140Nm	M b max 239Nm
	F t di 330N	F t peak 570N	F t max 990N
	F a di 330N	F a peak 570N	F a max 990N
LHD-20	M b di 117Nm	M b peak 230Nm	M b max 468Nm
	F t di 550N	F t peak 975N	F t max 1680N
	F a di 550N	F a peak 975N	F a max 1680N
LHD-25	M b di 213Nm	M b peak 420Nm	M b max 855Nm
	F t di 790N	F t peak 1400N	F t max 2450N
	F a di 790N	F a peak 1400N	F a max 2450N
LHD-32	M b di 400Nm	M b peak 800Nm	M b max 1600Nm
	F t di 1240N	F t peak 2100N	F t max 3680N
	F a di 1240N	F a peak 2100N	F a max 3680N
LHD-40	M b di 600Nm	M b peak 1200Nm	M b max 2520Nm
	F t di 1530N	F t peak 2670N	F t max 4600N
	F a di 1530N	F a peak 2670N	F a max 4600N

■ Note: Output load Mb- Bending moment, Ft-radial force, Fa-axial force

# LSS - 14 - 100 - U/C - I

Series	Type	Reduction ratio(Note 1)						Structure code	Style
LSS	11	50	80	100	-	-	-	U: Completely unit C: Component	I: Simple Standard Type II: Simple Cross Slider type
LSN	14	50	80	100	-	-	-		
LSG	17	50	80	100	-	-	-		
LSD	20	50	80	100	120	160	-		
LFS	25	50	80	100	120	-	-		

Note1: Reduction ratio indicates of wave generator as inputting, fixing circular spline, and flexspline as outputting.

## LSS series



### LSS series

A combination product which is easy to operate. Each model has a cross-roller bearing that with high rigidity to support external loads.

### LSN series

A light weight product. Compare with standard product that with the same performance, LSN series is 30% lighter.

### LSG series

High torque. Compare with standard products, LSG series' torque capacity is 30% higher. And the service life is increased by 43%, with high load capacity and high reliability.

### Application

- Industrial robot
- Service Robots
- Metal Machine Tools
- Medical Devices
- Analysis, Test Equipment
- Energy Related equipment
- Papermaking Equipment

## Combinative structure of LSS series

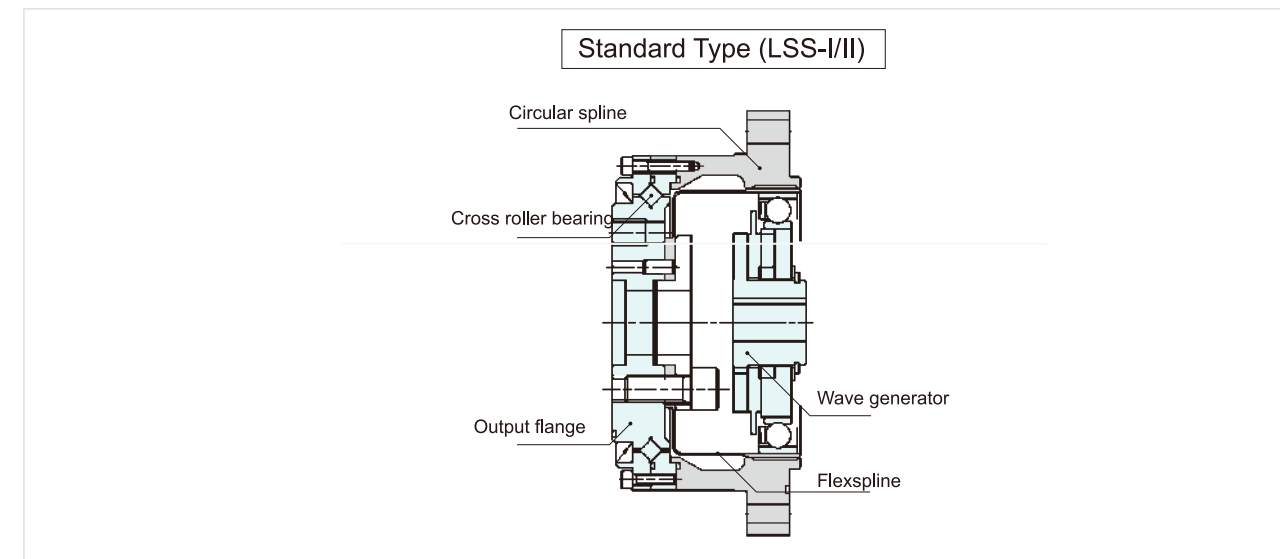

## Rated parameter table of LSS/LSN series

Model	Reduction ratio	Rated torque at 2000r/min input		Permissible peak torque at start and stop		Permissible maximum value for average load torque		Permissible maximum momentary torque		Permissible maximum input rotational speed(Grease)		Permissible average input rotational speed(Grease)		Moment of inertia kgcm <sup>2</sup>
		Nm	Kgfm	Nm	Kgfm	Nm	Kgfm	Nm	Kgfm	r/min	r/min	r/min	r/min	
11	50	3.5	0.55	8.3	1.8	5.5	0.70	17.0	3.6	8500	3500	1.4×10 <sup>-2</sup> 1.2×10 <sup>-2</sup>		
	80	4.5	0.80	9.9	2.4	8.0	1.1	22.5	4.8					
	100	5.0	0.80	11	2.9	8.9	1.1	25.0	5.5					

Model	Reduction ratio	Rated torque at 2000r/min input		Permissible peak torque at start and stop		Permissible maximum value for average load torque		Permissible maximum momentary torque		Permissible maximum input rotational speed(Grease)		Permissible average input rotational speed(Grease)		backlash Arc Sec	Design life Hour
		Nm	Kgfm	Nm	Kgfm	Nm	Kgfm	Nm	Kgfm	r/min	r/min	r/min	r/min		
14	50	5.4	0.55	18	1.8	6.9	0.70	35	3.6	8500	3500	≤20	10000 15000 15000 15000		
	80	7.8	0.80	23	2.4	11	1.1	47	4.8						
	100	7.8	0.80	28	2.9	11	1.1	54	5.5						
	120	7.8	0.80	28	2.9	11	1.1	54	5.5						
17	50	16	1.6	34	3.5	26	2.6	70	7.1	7300	3500	≤20	10000 15000 15000 15000		
	80	22	2.2	43	4.4	27	2.7	87	8.9						
	100	24	2.4	54	5.5	39	4.0	108	11						
	120	24	2.4	54	5.5	39	4.0	86	8.8						
20	50	25	2.5	56	5.7	34	3.5	98	10	6500	3500	≤20	10000 15000 15000 15000		
	80	34	3.5	74	7.5	47	4.8	127	13						
	100	40	4.1	82	8.4	49	5.0	147	15						
	120	40	4.1	87	8.9	49	5.0	147	15						
25	50	39	4.0	98	10	55	5.6	186	19	5600	3500	≤20	10000 15000 15000 15000		
	80	63	6.4	137	14	87	8.9	255	26						
	100	67	6.8	157	16	108	11	284	29						
	120	67	6.8	167	17	108	11	304	31						
32	50	76	7.8	216	22	108	11	382	39	4800	3500	≤20	10000 15000 15000 15000		
	80	118	12	304	31	167	17	568	58						
	100	137	14	333	34	216	22	647	66						
	120	137	14	353	36	216	22	686	70						
40	50	137	14	402	41	196	20	686	70	4000	3000	≤20	10000 15000 15000 15000		
	80	206	21	519	53	284	29	980	100						
	100	265	27	568	58	372	38	1080	110						
	120	294	30	617	63	451	46	1180	120						

## Rated parameter table of LSG series

Model	Reduction ratio	Rated torque at 2000r/min input		Permissible peak torque at start and stop		Permissible maximum value for average load torque		Permissible maximum momentary torque		Permissible maximum input rotational speed(Grease)		Permissible average input rotational speed(Grease)		backlash Arc Sec	Design life Hour
		Nm	Kgfm	Nm	Kgfm	Nm	Kgfm	Nm	Kgfm	r/min	r/min	r/min	r/min		
11	80	3.8	0.4	8.5	0.9	6.8	0.7	19.1	1.9	8000	3000	≤20	10000		
	100	4.1	0.4	8.9	0.9	7.2	0.7	20	2						
14	50	7	0.7	23	2.3	9	0.9	46	4.7	10000	6500	≤20	15000		
	80	10	1	30	3.1	14	1.4	61	6.2						
17	50	21	2.1	44	4.5	34	3.4	91	9	7500	5600	≤20	20000		
	80	29	2.9	56	5.7	35	3.6	113	12						
20	50	33	3.3	73	7.4	44	4.5	127	13	7000	4800	≤20	20000		
	80	44	4.5	96	9.8	61	6.2	165	17						
	100	52	5.3	107	10.9	64	6.5	191	20						
	120	52	5.3	113	11.5	64	6.5	191	20						
25	50	51	5.2	127	13	72	7.3	242	25	5600	4000	≤20	20000		
	80	82	8.4	178	18	113	12	332	34						
	100	87	8.9	204	21	140	14	369	38						
32	50	99	10	281	29	140	14	497	51	5600	3000	≤20	20000		
	80	153	16	395	40	217	22	738	75						
	100	178	18	433	44	281	29	841	86						
	120	178	18	459	47	281	29	892	91						

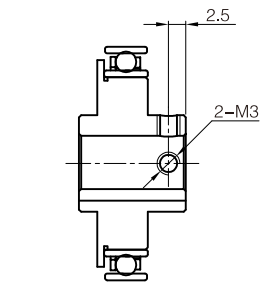
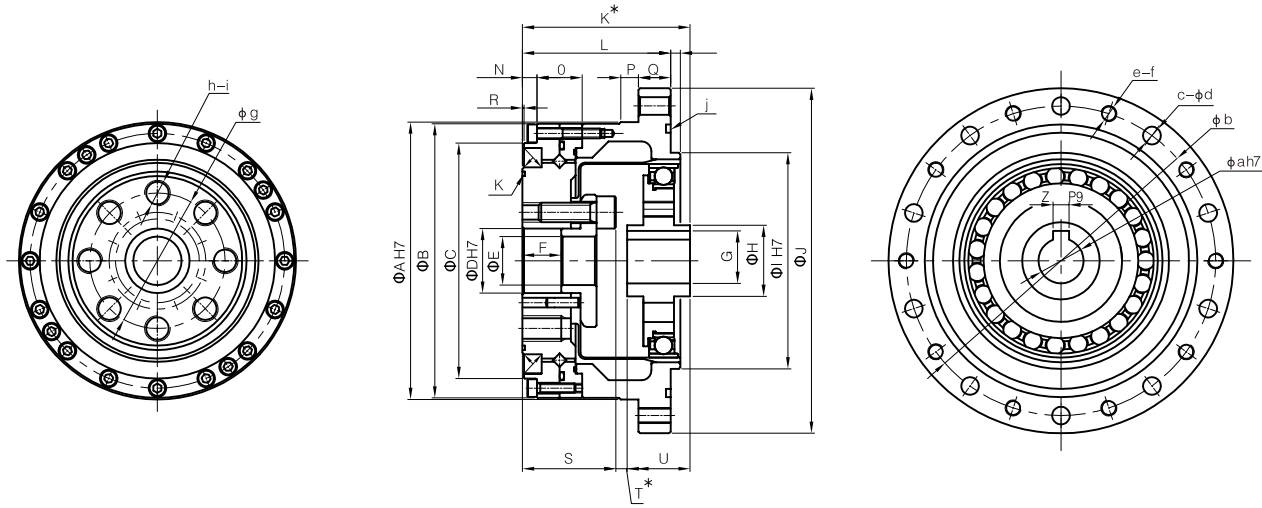

The generator inner hole of type 14 is non-keyway

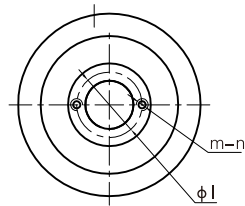

Generator's location limited mounting hole

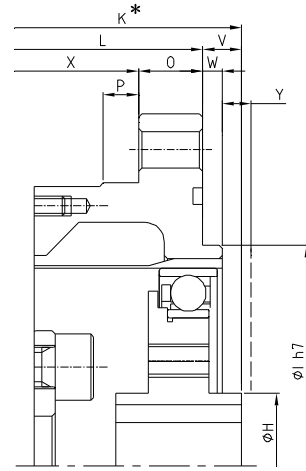

Enlarged drawing of input end

Note:

- Please noted that the length of bolt mesh should be kept within the depth of internal thread. If it exceeded symbol i size, the flexspline will be damaged.
- $\psi E$  position is through-hole shape which leads to inside of the product. The size of \* in figure is reference dimension of installation, please comply with requirements of such installation size.
- The output flange will be different based on each type. For details, please contact our authorized distributor.

\*For detailed information of product, please confirm it with delivery specification figure.

Type	14	17	20	25	32	
Symbol						
$\Phi A h7$	56	63	72	86	113	
$\Phi B$	55	62	70	85	112	
$\Phi C$	42.5	49.5	58	73	96	
$\Phi D H7$	11	10	14	20	26	
$\Phi E$	8	7	10	15	20	
$\Phi F$	9.4	9.5	9	12	14.2	
G	$9.4^{+0.1}_0$	$9.4^{+0.1}_0$	$9.4^{+0.1}_0$	$16.3^{+0.1}_0$	$21.8^{+0.1}_0$	
$\Phi H$	14	16	22	22	35	
$\Phi I h7$	38	48	56	67	90	
$\Phi J$	73	79	93	107	138	
K	41	45	45.5	52	62	
L	36	37	38	46	57	
M	2	2	3	3	3	
N	4.5	2.5	4	3.5	5.3	
O	12	12	12.5	14	17	
P	4	4	5.5	5.5	5.5	
Q	7	8	10	10	12	
R	0.5	0.5	0.5	0.5	1	
S	21.4	23.5	23	29	36.2	
T	4.1	2.5	4	3.5	5.3	
U	$15.5^{+0.1}_0$	$19^{+0.1}_0$	$18.5^{+0.1}_0$	$19.5^{+0.1}_0$	$20.5^{+0.1}_0$	
V	5	6	4.5	6	5	
X	27	29	28	36	45	
Y	1	1	1.5	1.5	1.5	
Z P9	3	3	3	5	6	
$\Phi a H7$	8	8	8	14	19	
$\Phi b$	65	71	82	96	125	
c	LSS/LSG	8	8	10	12	
	LSSF	6	6	6	8	12
$\Phi d$	4.5	4.5	5.5	5.5	6.5	
e	LSS/LSG	8	8	8	10	12
	LSSF	6	6	6	10	12
f	M4	M4	M5	M5	M6	
$\Phi g$	23	27	32	42	55	
h	6	6	8	8	8	
i	M4	M5	M6	M8	M10	
j	50x2	56x2	67x2	80x2	105x2	
k	29x0.5	34.5x0.8	40.5x1.2	53x1	69x2	
$\Phi l$	/	12	18	18	26	
m	/	2	2	2	2	
n	/	M2.5	M2.5	M2.5	M3	

- The size marked with \* symbol refers to the axial connection position and tolerance of three parts, which are wave generator, flexspline, circular spline. The size will have an influence on performance and intensity, therefore, please strictly abide by it.
- There is also difference in tolerance owing to different manufacturing method (casting and machining) for parts and components. For size without giving clear indication of tolerance, please contact with our company or authorized distributor if you needed more information.
- Wave generator is individually packaged when delivering the product.



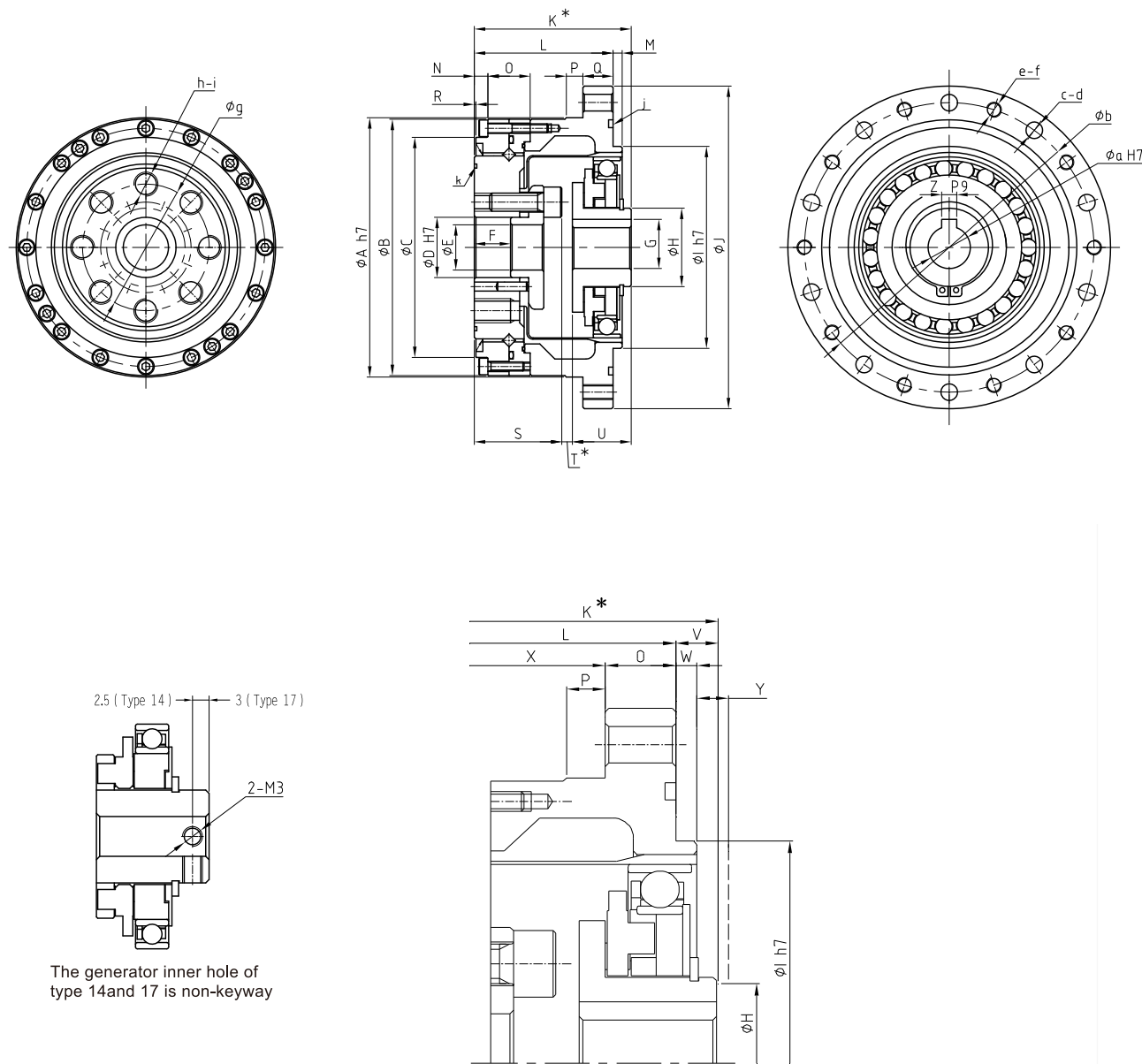

The generator inner hole of type 14 and 17 is non-keyway

- Note:
- Please noted that the length of bolt mesh should be kept within the depth of internal thread. If it exceeded symbol i size, the flexspline will be damaged.
  - $\psi$ E position is through-hole shape which leads to inside of the product. The size of \* in figure is reference dimension of installation, please comply with requirements of such installation size.
  - The output flange will be different based on each type. For details, please contact our authorized distributor.
  - For detailed information of product, please confirm it with delivery specification figure.

Type	14	17	20	25	32
$\Phi$ A h7	56	63	72	86	113
$\Phi$ B	55	62	70	85	112
$\Phi$ C	42.5	49.5	58	73	96
$\Phi$ D H7	11	10	14	20	26
$\Phi$ E	8	7	10	15	20
$\Phi$ F	9.4	9.5	9	12	14.2
G	/	/	$12.8^{+0.1}_0$	$16.3^{+0.1}_0$	$16.3^{+0.1}_0$
$\Phi$ H	14	18	21	26	26
$\Phi$ I h7	38	48	56	67	90
$\Phi$ J	73	79	93	107	138
K	41	45	45.5	52	62
L	34	37	38	46	57
M	2	2	3	3	3
N	4.5	4.5	4	4.5	5.5
O	7	12	12.5	14	17
P	4	4	5.5	5.5	5.5
Q	7	8	10	10	12
R	0.5	0.5	0.5	0.5	1
S	21.4	23.5	23	29	36.2
T	2	2	2.4	2.8	3.8
U	$17.6^{+0}_-0.1}$	$19.5^{+0}_-0.1}$	$20.1^{+0}_-0.1}$	$20.2^{+0}_-0.1}$	$22^{+0}_-0.1}$
V	2	8	7.5	6	5
X	27	29	28	36	45
Y	1	1	1.5	1.5	1.5
Z P9	/	/	4	5	5
$\Phi$ a H7	6	8	11	14	14
$\Phi$ b	65	71	82	96	125
c	LSS/LSG	8	8	10	12
	LSSF	6	6	8	12
$\Phi$ d	4.5	4.5	5.5	5.5	6.5
e	LSS/LSG	8	8	10	12
	LSSF	6	6	8	12
f	M4	M4	M5	M5	M6
$\Phi$ g	23	27	32	42	55
h	6	6	8	8	8
i	M4	M5	M6	M8	M10
j	50x2	56x2	67x2	80x2	105x2
k	29x0.5	34.5x0.8	40.5x1.2	53x1	69x2

- The size marked with \* symbol refers to the axial connection position and tolerance of three parts, which are wave generator, flexspline, circular spline. The size will have an influence on performance and intensity, therefore, please strictly abide by it.
- There is also difference in tolerance owing to different manufacturing method (casting and machining) for parts and components. For size without giving clear indication of tolerance, please contact with our company or authorized distributor if you needed more information.
- Wave generator is individually packaged when delivering the product.

# LSD Series



LSD-I

## LSD Series

This miniaturized product was developed according to the marketing demand. Compare with LSS series that with the same torque capacity, LSD series is more compact and thin-walled, smaller size.

### Application

- Industrial robot
- Service Robots
- Metal Machine Tools
- Printed circuit manufacturing equipment
- Wood, light metal, plastic machine tools

# LSD-I series

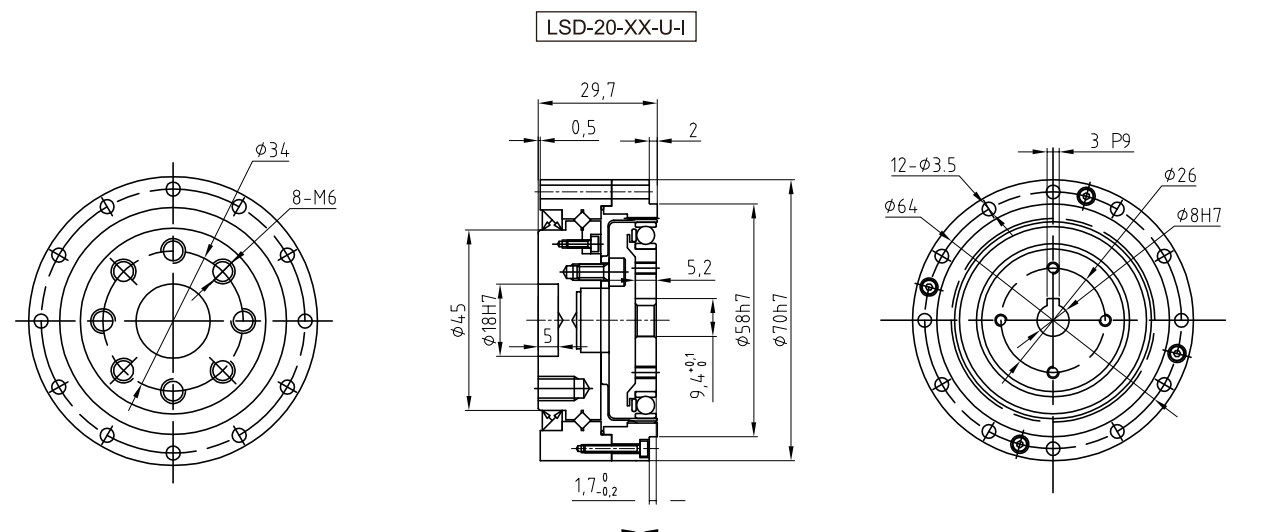
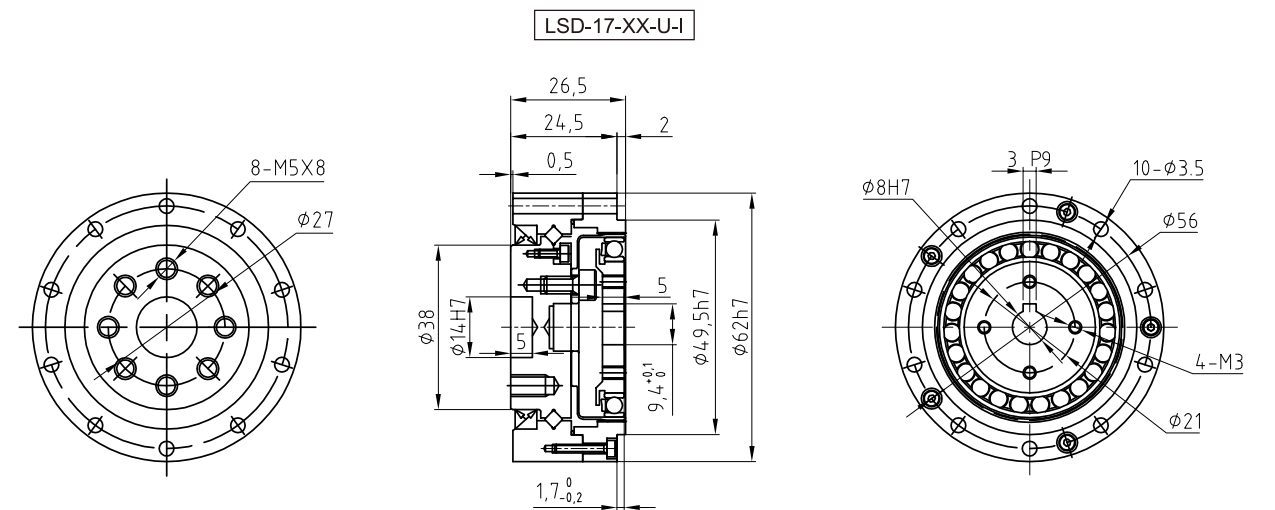
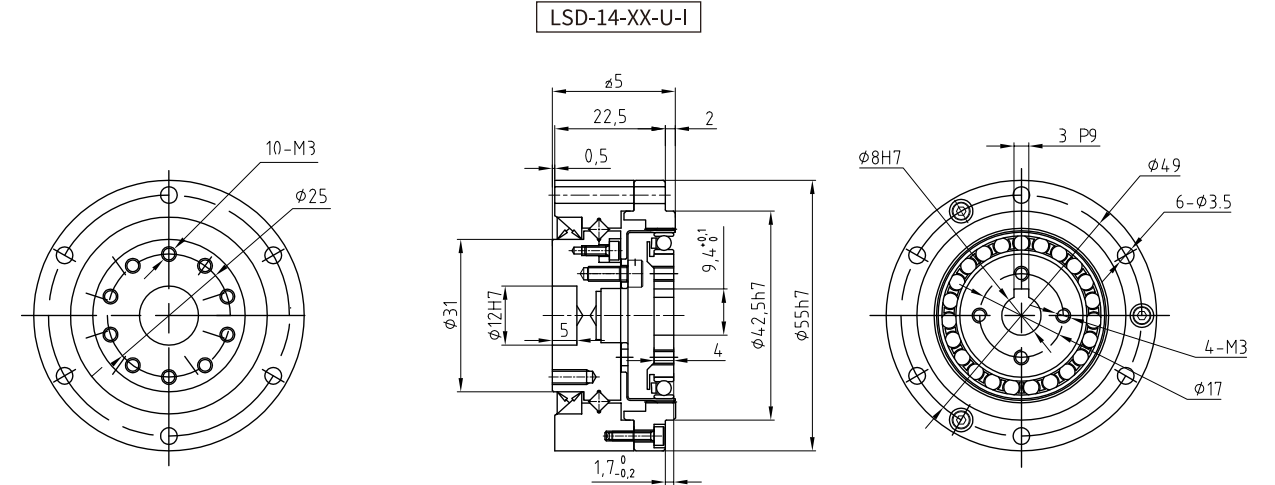

For detailed information of product, please confirm it with delivery specification figure

## Combinative structure of LSD series

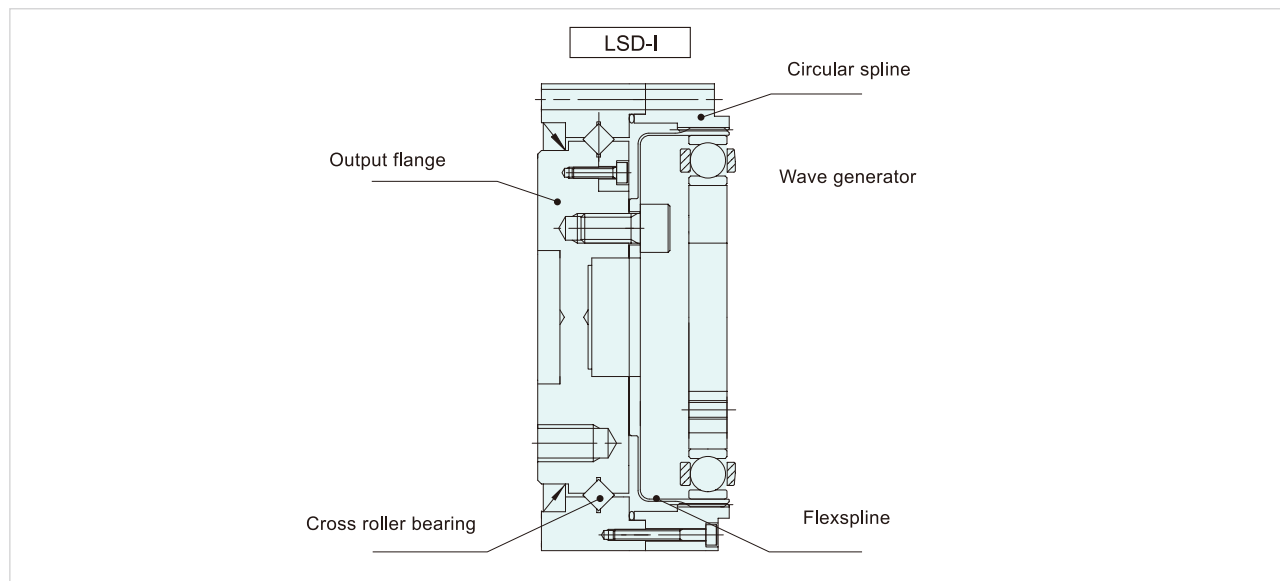

## Rated parameter table of LSD series

Model	Reduction ratio	Rated torque at 2000r/min input		Permissible peak torque at start and stop		Permissible maximum value for average load torque		Permissible maximum momentary torque		Permissible maximum input rotational speed(Grease)		Permissible average input rotational speed(Grease)		backlash	Design life
		Nm	Kgfm	Nm	Kgfm	Nm	Kgfm	Nm	Kgfm	r/min	r/min	Arc Sec	Hour		
14	50	3.7	0.38	12	1.2	4.8	0.49	24	2.4	8500	3500	≤20	7000		
	80	4.2	0.43	16	1.6	5.9	0.6	31	3.1						
	100	5.4	0.55	19	1.9	7.7	0.79	35	3.6						
17	50	11	1.1	23	2.3	18	1.9	48	4.9	7300	3500	≤20	10000		
	80	14	1.4	30	0.3	21	2.1	58	5.9						
	100	16	1.6	37	3.8	27	2.8	71	7.2						
20	50	17	1.7	39	4.0	24	2.4	69	7.0	6500	3500	≤20	10000		
	80	21	2.1	46	4.7	30	3.1	81	0.8						
	100	28	2.9	57	5.8	34	3.5	95	9.7						



**LFS series**  
A combination product that with light weight, ultra-flat. Using cross-roller bearing.

**LFS Integrated series**  
Combined harmonic reducer with the high-performance small motor, with the highest input characteristics under the same gear conditions.

**Application**

- Industrial robot
- Service Robots
- Medical Devices
- Automation and special equipment

**LFS-I**      **LFS Integrated series**

Rated parameter table of LFS series

Model	Reduction ratio	Rated torque at 2000r/min input		Permissible peak torque at start and stop		Permissible maximum value for average load torque		Permissible maximum momentary torque		Permissible maximum input rotational speed(Grease)		backlash	Design life
		Nm	Kgfm	Nm	Kgfm	Nm	Kgfm	Nm	Kgfm	r/min	r/min		
11	50	3.5	0.4	8.3	0.9	5.5	0.6	17	1.7	8500	3000	≤20	10000
	80	5	0.5	11	1.1	8.9	0.9	25	2.5				
	100	5	0.5	11	1.1	8.9	0.9	25	2.5				
14	50	5.4	0.6	18	1.8	6.9	0.7	35	3.6	8500	3000	≤20	10000
	80	7.8	0.8	28	2.9	11	1.1	54	5.5				
	100	7.8	0.8	28	2.9	11	1.1	54	5.5				

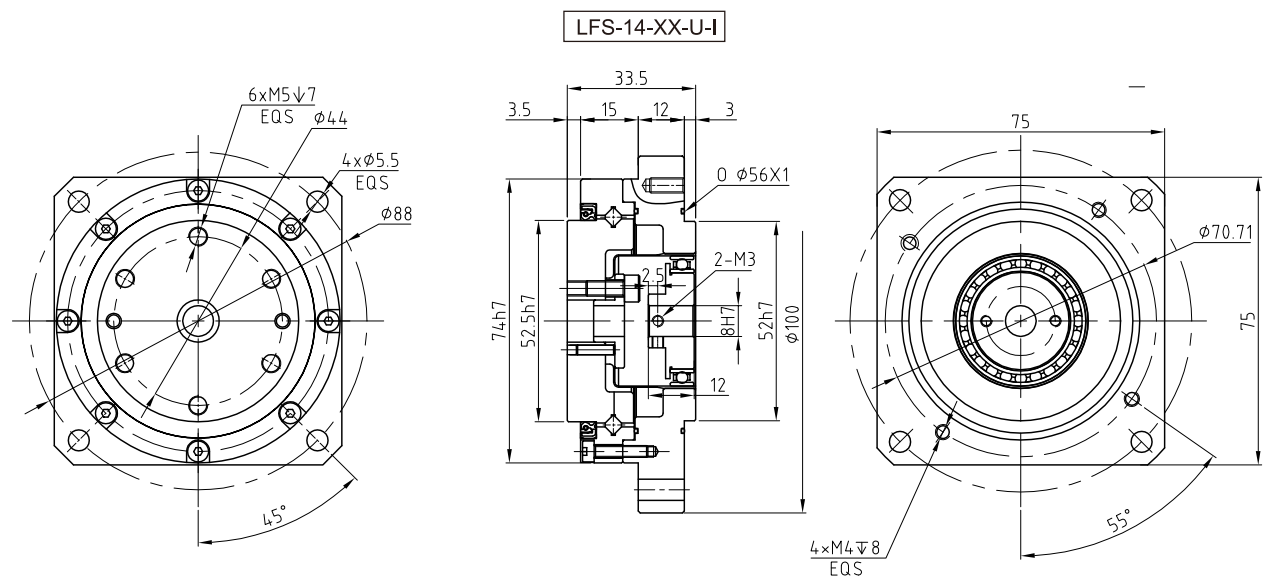
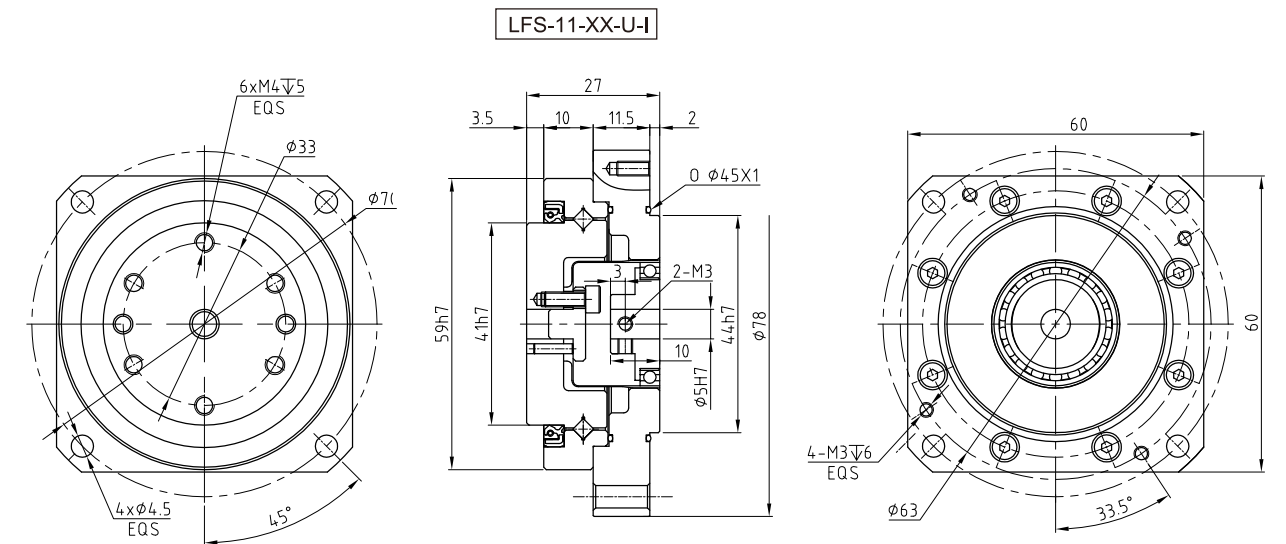

For detailed information of product, please confirm it with delivery specification figure..



# LHT series



Hollow type (LHT-III)

Input axial type (LHT-IV)



Simple type (LHT-II/LHT-I)

Simple type (LHT-V)

## LHT series

A combination product that with large diameter hollow hole, flat shape, which is easy to operate.

## LHN series

Light weight product, 20% lighter than standard products.

## LHG series

High torque. Compare with standard products, LHG series' torque capacity is 30% higher. And the service life is increased by 43%, with high load capacity and high reliability.

## Application

- Industrial robot
- Service Robots
- Medical Devices
- Automation and special equipment
- Printed circuit manufacturing equipment

## Combinative structure of LHT series

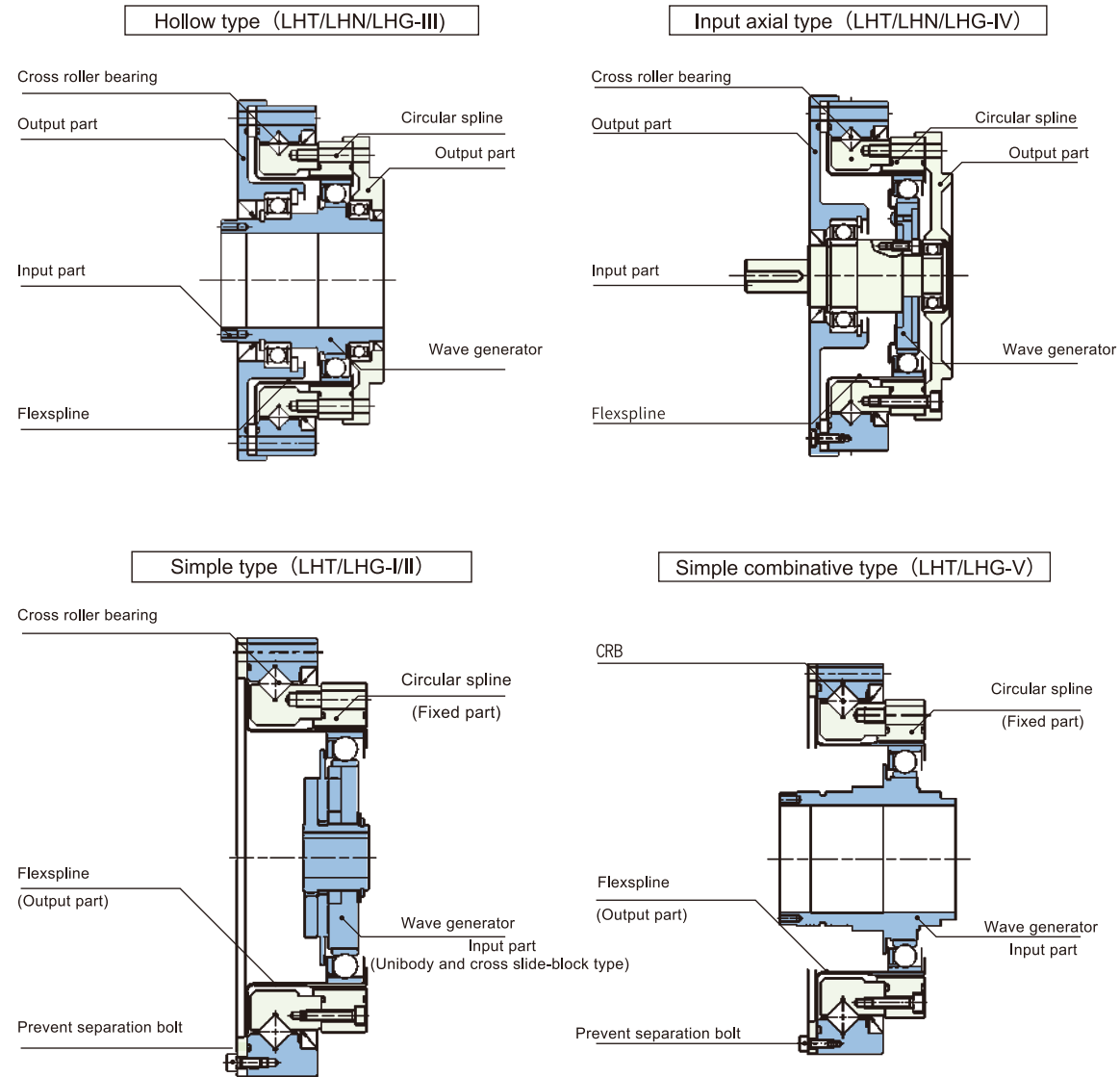

## Rated parameter table of LHT/LHN series

Model	Reduction ratio	Rated torque at 2000r/min input		Permissible peak torque at start and stop		Permissible maximum value for average load torque		Permissible maximum momentary torque		Permissible maximum input rotational speed(Grease)	Permissible average input rotational speed(Grease)	Backlash	Desian life
		Nm	kgfm	Nm	kgfm	Nm	kgfm	Nm	kgfm				
14	50	5.4	0.55	18	1.8	6.9	0.70	35	3.6	8500	3500	≤20	10000
	80	7.8	0.80	23	2.4	11	1.1	47	4.8				15000
	100	7.8	0.80	28	2.9	11	1.1	54	5.5				15000
	120	7.8	0.80	28	2.9	11	1.1	54	5.5				15000
17	50	16	1.6	34	3.5	26	2.6	70	7.1	7300	3500	≤20	10000
	80	22	2.2	43	4.4	27	2.7	87	8.9				15000
	100	24	2.4	54	5.5	39	4.0	110	11				15000
	120	24	2.4	54	5.5	39	4.0	86	8.8				15000
20	50	25	2.5	56	5.7	34	3.5	98	10	6500	3500	≤20	10000
	80	34	3.5	74	7.5	47	4.8	127	13				15000
	100	40	4.1	82	8.4	49	5.0	147	15				15000
	120	40	4.1	87	8.9	49	5.0	147	15				15000
25	50	39	4.0	98	10	55	5.6	186	19	5600	3500	≤20	10000
	80	63	6.4	137	14	87	8.9	255	26				15000
	100	67	6.8	157	16	108	11	284	29				15000
	120	67	6.8	167	17	108	11	304	31				15000
32	50	76	7.8	216	22	108	11	382	39	4800	3500	≤20	10000
	80	118	12	304	31	167	17	568	58				15000
	100	137	14	333	34	216	22	647	66				15000
	120	137	14	353	36	216	22	686	70				15000
40	50	137	14	402	41	196	20	686	70	4000	3000	≤20	10000
	80	206	21	519	53	284	29	980	100				15000
	100	265	27	568	58	372	38	1080	110				15000
	120	294	30	617	63	451	46	1180	120				15000

## Rated parameter table of LHG series

Model	Reduction ratio	Rated torque at 2000r/min input		Permissible peak torque at start and stop		Permissible maximum value for average load torque		Permissible maximum momentary torque		Permissible maximum input rotational speed(Grease)	Permissible average input rotational speed(Grease)	Backlash	Desian life
		Nm	kgfm	Nm	kgfm	Nm	kgfm	Nm	kgfm				
14	50	7	0.7	23	2.3	9	0.9	46	4.7	8500	3500	≤20	10000
	80	10	1.0	30	3.1	14	1.4	61	6.2				15000
	100	10	1.0	36	3.7	14	1.4	70	7.2				15000
	120	10	1.0	36	3.7	14	1.4	70	7.2				15000
17	50	21	2.1	44	4.5	34	3.4	91	9	7300	3500	≤20	10000
	80	29	2.9	56	5.7	35	3.6	113	12				15000
	100	31	3.2	70	7.2	51	5.2	143	15				15000
	120	31	3.2	70	7.2	51	5.2	112	11				15000
20	50	33	3.3	73	7.4	44	4.5	127	13	6500	3500	≤20	10000
	80	44	4.5	96	9.8	61	6.2	165	17				15000
	100	52	5.3	107	10.9	64	6.5	191	20				15000
	120	52	5.3	113	11.5	64	6.5	191	20				15000
25	50	51	5.2	127	13	72	7.3	242	25	5600	3500	≤20	10000
	80	82	8.4	178	18	113	12	332	34				15000
	100	87	8.9	204	21	140	14	369	38				15000
	120	87	8.9	217	22	140	14	395	40				15000
32	50	99	10	281	29	140	14	497	51	4800	3500	≤20	10000
	80	153	16	395	40	217	22	738	75				15000
	100	178	18	433	44	281	29	841	86				15000
	120	178	18	459	47	281	29	892	91				15000
40	50	178	18	523	53	255	26	892	91	4000	3000	≤20	10000
	80	268	27	675	69	369	38	1270	130				15000
	100	345	35	738	75	484	49	1400	143				15000
	120	382	39	802	82	586	60	1530	156				15000

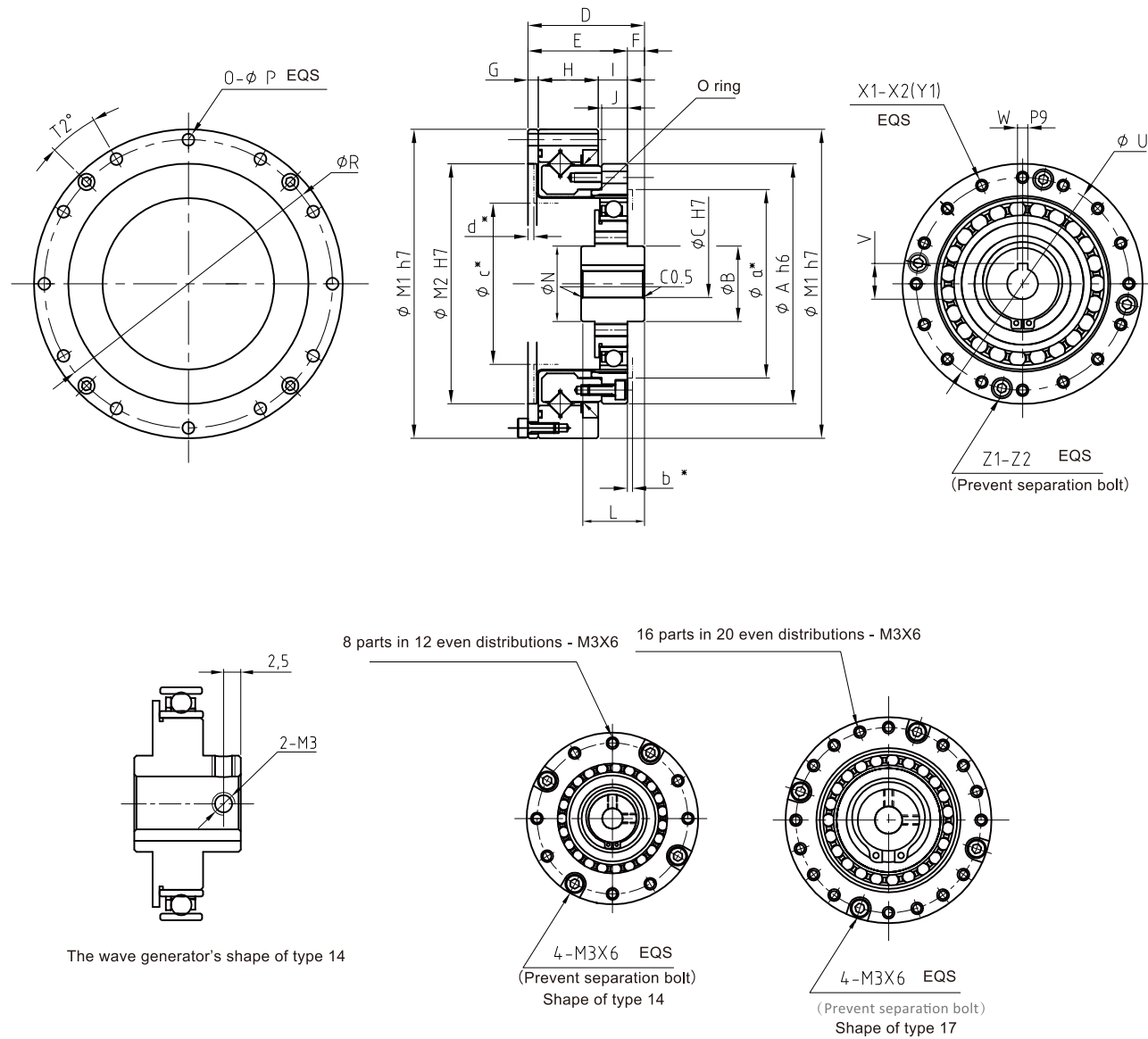

The wave generator's shape of type 14

4-M3X6 EQS  
(Prevent separation bolt)  
Shape of type 14

4-M3X6 EQS  
(Prevent separation bolt)  
Shape of type 17

For detailed information of product, please confirm it with delivery specification figure.

Type	14	17	20	25	32
Symbol					
ΦAh6	50	60	70	85	110
ΦB	14	16	22	24	35
ΦCH7	8	8	8	14	19
D	28.5 <sup>0</sup> <sub>-0.1</sub>	32.5 <sup>0</sup> <sub>-0.1</sub>	33.5 <sup>0</sup> <sub>-0.1</sub>	37 <sup>0</sup> <sub>-0.1</sub>	44 <sup>0</sup> <sub>-0.1</sub>
E	23.5	26.5	29	34	42
F	5	6	4.5	3	2
G	2.4	3	3	3.3	3.6
H	14.1	16	17.5	18.7	23.4
I	7	7.5	8.5	12	15
J	6	6.5	7.5	10	14
L	15.5 <sup>0</sup> <sub>-0.1</sub>	19 <sup>0</sup> <sub>-0.1</sub>	18.5 <sup>0</sup> <sub>-0.1</sub>	19.5 <sup>0</sup> <sub>-0.1</sub>	20.5 <sup>0</sup> <sub>-0.1</sub>
M1h7	70	80	90	110	142
M2H7	48#	60	70	88	114
ΦN	14	16	22	22	35
O	8	12	12	12	12
ΦP	3.5	3.5	3.5	4.5	5.5
ΦR	64	74	84	102	132
T2(Angle)	22.5°	15°	15°	15°	15°
ΦU	44	54	62	77	100
V	9.4 <sup>+0.1</sup> <sub>0</sub>	9.4 <sup>+0.1</sup> <sub>0</sub>	9.4 <sup>+0.1</sup> <sub>0</sub>	16.3 <sup>+0.1</sup> <sub>0</sub>	21.8 <sup>+0.1</sup> <sub>0</sub>
WP9	3	3	3	5	6
X1	8 parts in 12 even distributions	16 parts in 20 even distributions	16	16	16
X2	M3×6	M3×6	M3×6	M4×8	M5×10
Y1	3.5×6	3.5×6.5	3.5×7.5	4.5×10	5.5×14
Z1	4	4	4	4	4
Z2	M3×6	M3×6	M3×8	M3×10	M4×16
Φα	36.5	45	54.5	64.5	86
b	1	1	1.5	1.5	2
Φc	31	38	48	58	77
d	1.2	1.7	1.7	1.9	2.1
Φe	/	12	18	18	26
f	/	2	2	2	2
g	/	M2.5	M2.5	M2.5	M3

- The size marked with \* symbol refers to the axial connection position and tolerance of three parts, which are wave generator, flexspline, circular spline. The size will have an influence on performance and intensity, therefore, please strictly abide by it.
- There is also difference in tolerance owing to different manufacturing method (casting and machining) for parts and components. For size without giving clear indication of tolerance, please contact with our company or authorized distributor if you needed more information.
- Owing to flexspline can be distorted, please use inwall size greater than φa.b.c and lesser than d in order to prevent it from being in touch with shell.
- Wave generator is individually packaged when delivering the product.
- The size marked # can be customized according to customer's requirement. For more details, please consult with our authorized distributor.

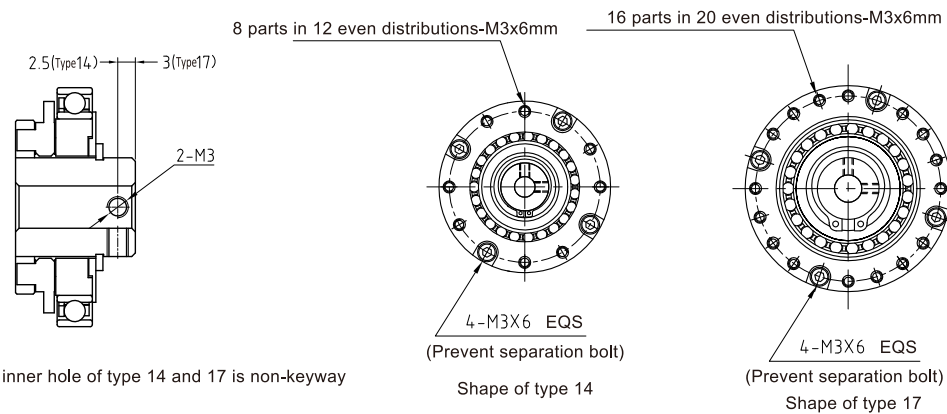
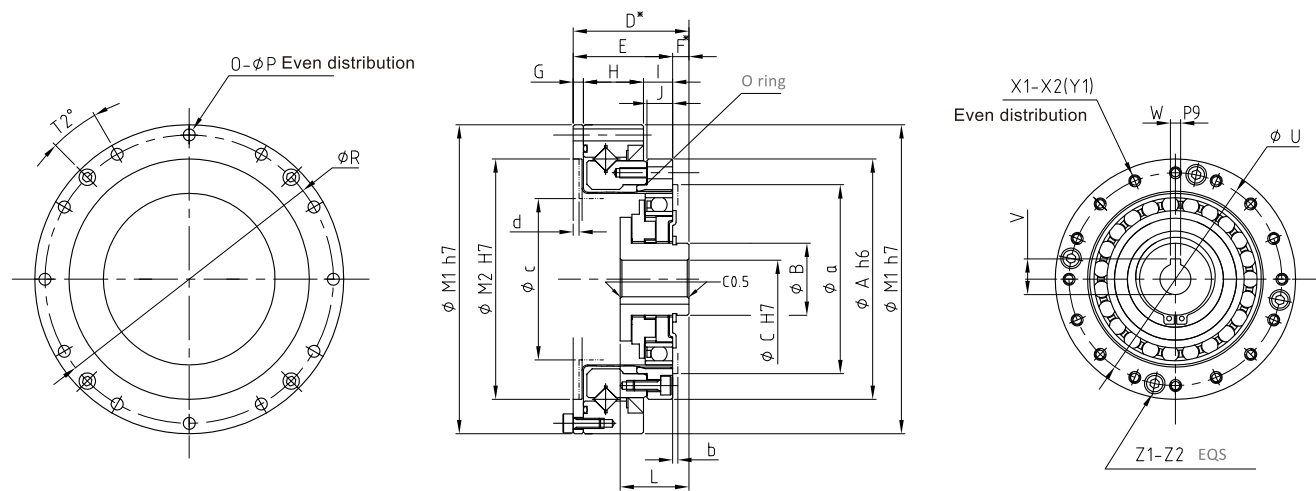

The generator inner hole of type 14 and 17 is non-keyway

Shape of type 14

Shape of type 17

Size chart

Type	14	17	20	25	32
Symbol					
ΦAh6	50	60	70	85	110
ΦB	14	18	21	26	26
ΦCH7	6	8	11	14	14
D	28.5 <sup>0</sup> <sub>-0.1</sub>	32.5 <sup>0</sup> <sub>-0.1</sub>	33.5 <sup>0</sup> <sub>-0.1</sub>	37 <sup>0</sup> <sub>-0.1</sub>	44 <sup>0</sup> <sub>-0.1</sub>
E	23.5	26.5	29	34	42
F	5	6	4.5	3	2
G	2.4	3	3	3.3	3.6
H	14.1	16	17.5	18.7	23.4
I	7	7.5	8.5	12	15
J	6	6.5	7.5	10	14
L	17.6 <sup>0</sup> <sub>-0.1</sub>	19.5 <sup>0</sup> <sub>-0.1</sub>	20.1 <sup>0</sup> <sub>-0.1</sub>	20.2 <sup>0</sup> <sub>-0.1</sub>	22 <sup>0</sup> <sub>-0.1</sub>
M1h7	70	80	90	110	142
M2H7	48#	60	70	88	114
O	8	12	12	12	12
ΦP	3.5	3.5	3.5	4.5	5.5
ΦR	64	74	84	102	132
T2(Angel)	22.5°	15°	15°	15°	15°
ΦU	44	54	62	77	100
V	/	/	12.8 <sup>+0.1</sup> <sub>0</sub>	16.3 <sup>+0.1</sup> <sub>0</sub>	16.3 <sup>+0.1</sup> <sub>0</sub>
WP9	/	/	4	5	5
X1	8 part in 12 even distributions	16 part in 20 even distributions	16	16	16
X2	M3×6	M3×6	M3×6	M4×8	M5×10
Y1	3.5×6	3.5×6.5	3.5×7.5	4.5×10	5.5×14
Z1	4	4	4	4	4
Z2	M3×6	M3×6	M3×8	M3×8	M4×10
Φα	36.5	45	54.5	64.5	86
b	1	1	1.5	1.5	2
ΦC	31	38	48	58	77
d	1.2	1.7	1.7	1.9	2.1

- The size marked with \* symbol refers to the axial connection position and tolerance of three parts, which are wave generator, flexspline, circular spline. The size will have an influence on performance and intensity, therefore, please strictly abide by it.
- There is also difference in tolerance owing to different manufacturing method(casting and machining) for parts and components. For size without giving clear indication of tolerance, please contact with our company or authorized distributor if you needed more information.
- Owing to flexspline can be distorted, please use inwall size greater than φa.b.c and lesser than d in order to prevent it from being in touch with shell.
- Wave generator is individually packaged when delivering the product.
- The size marked # can be customized according to customer's requirement. For more details, please consult with our authorized distributor.

■ For detailed information of product, please confirm it with delivery specification figure..



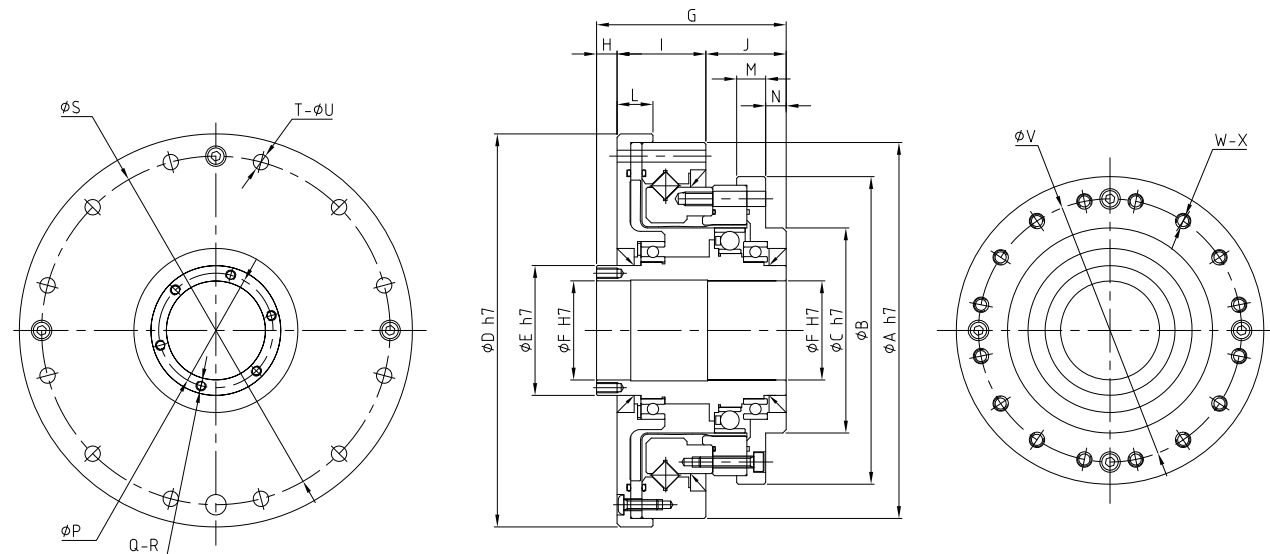

16 parts in 20 even distributions-M3x6mm

8 parts in 12 even distributions-M3x6mm

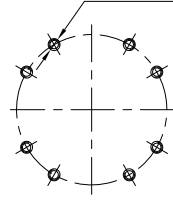
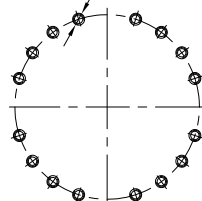

Type 17

Type 14

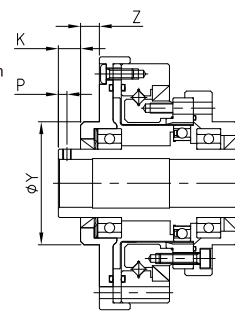

Input shape of type 14 and type 17

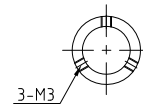

Type 14, 17

Type Symbol	14	17	20	25	32	40
ΦAh7	70	80	90	110	142	170
ΦB	54	64	75	90	115	140
ΦCh7	36	45	50	60	85	100
ΦDh7	74	84	95	115	147	175
ΦEh7	20	25	30	38	45	59
ΦFh7	14	19	21	29	36	46
G	52.5	56.5	51.5	55.5	65.5	79
H	12	12	5	6	7	8
I	20.5	23	25	26	32	38
J	20	21.5	21.5	23.5	26.5	33
k	6.5	6.5	/	/	/	/
L	9	10	10.5	10.5	12	14
M	8	8.5	9	8.5	9.5	13
N	7.5	8.5	7	6	5	7
ΦP(P)	(2.5)	(2.5)	25.5	33.5	40.5	52
Q	3	3	6	6	6	6
R	M3	M3	M3×6	M3×6	M3×6	M4×8
ΦS	64	74	84	102	132	158
T	8	12	12	12	12	12
ΦU	3.5	3.5	3.5	4.5	5.5	6.6
ΦV	44	54	62	77	100	122
W	8 part in 12 even distributions	16 part in 20 even distributions	16	16	16	16
X	M3×6 φ3.5×11.5	M3×6 φ3.5×12	M3×6 φ3.5×13.5	M4×8 φ4.5×15.5	M5×8 φ5.5×20.5	M6×10 φ6.6×25
ΦY	36	45	/	/	/	/
Z	55	5.5	/	/	/	/

■ For detailed information of product, please confirm it with delivery specification figure..

■ Owing to different manufacturing method for parts and components.  
For size without giving clear indication of tolerance, please contact with our company or authorized distributor if you needed more information.

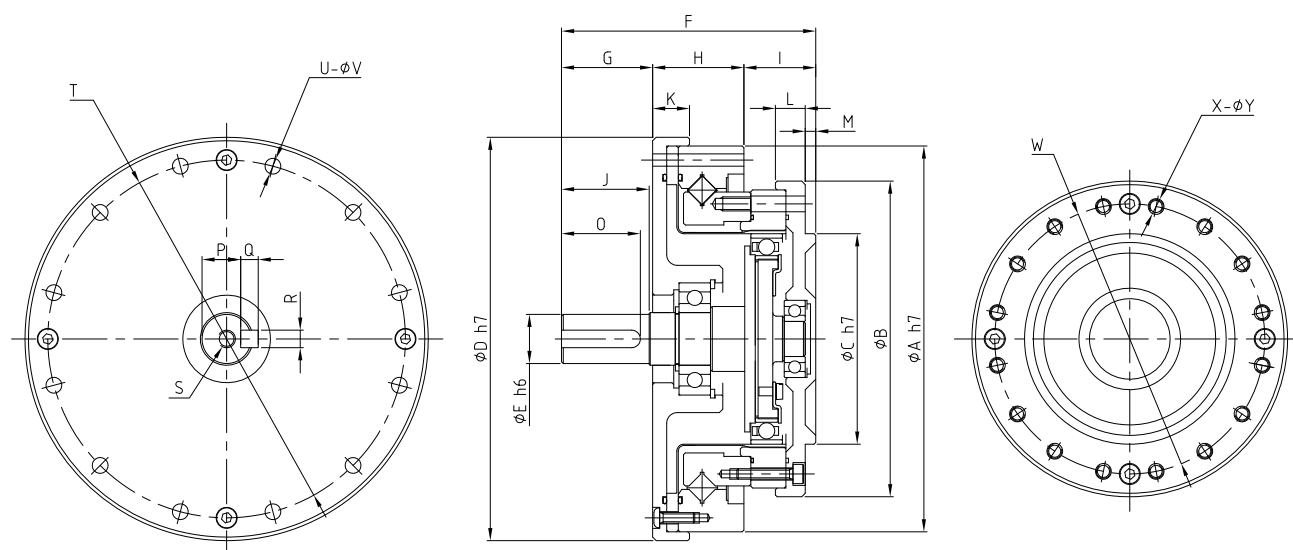

16 parts in 20 even distributions-M3x6mm

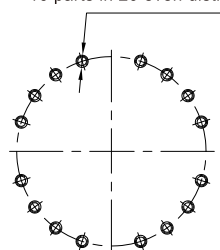

Type 17

8 parts in 12 even distributions-M3x6mm

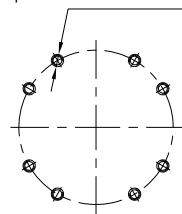

Type 14

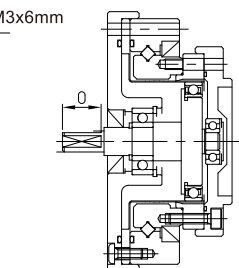

Input shape of type 14 and type 17

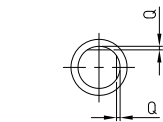

Enlarged drawing of type 14 and 17

■ For detailed information of product, please confirm it with delivery specification figure.

Type Symbol	14	17	20	25	32
ΦAh7	70	80	90	110	142
ΦB	54	64	75	90	115
ΦCh7	36	45	50	60	85
ΦDh7	74	84	95	115	147
ΦEh6	6	8	10	14	14
F	50.5	56	63.5	72.5	84.5
G	15	17	21	26	26
H	20.5	23	25	26	32
I	15	16	17.5	20.5	26.5
J	14	16	20	25	25
k	9	10	10.5	10.5	12
L	8	8.5	9	8.5	9.5
M	2.5	3	3	3	5
O	11	12	16.5	22.5	22.5
P	/	/	8.2 <sup>0</sup> <sub>-0.1</sub>	11 <sup>0</sup> <sub>-0.1</sub>	11 <sup>0</sup> <sub>-0.1</sub>
Q	0.5	0.5	3 <sup>0</sup> <sub>-0.025</sub>	5 <sup>0</sup> <sub>-0.03</sub>	5 <sup>0</sup> <sub>-0.03</sub>
R	/	/	3 <sup>0</sup> <sub>-0.025</sub>	5 <sup>0</sup> <sub>-0.03</sub>	5 <sup>0</sup> <sub>-0.03</sub>
S	/	/	M3×6	M5×10	M5×10
ΦT	64	74	84	102	132
U	8	12	12	12	12
ΦV	3.5	3.5	3.5	4.5	5.5
ΦW	44	54	62	77	100
X	8 part in 12 even distributions	16 part in 20 even distributions	16	16	16
Y	M3×6 3.5×11.5	M3×6 3.5×12	M3×6 3.5×13.5	M4×8 4.5×15.5	M5×8 5.5×20.5

■ owing to different manufacturing method for parts and components.  
For size without giving clear indication of tolerance, please contact with our company or authorized distributor if you needed more information.

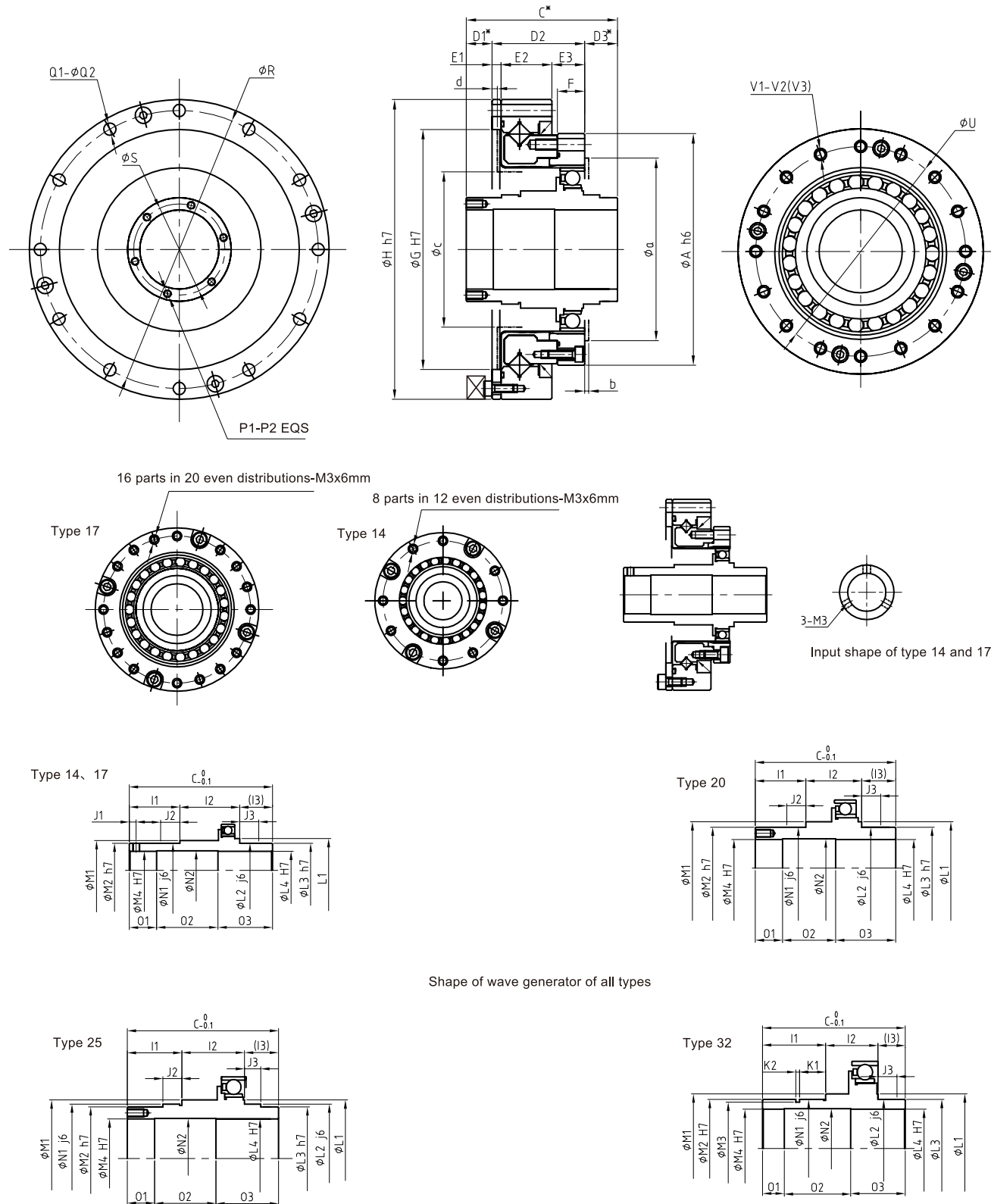

Shape of wave generator of all types

■ For detailed information of product, please confirm it with delivery specification figure.

Type	14	17	20	25	32
Symbol					
ΦAh6	50	60	70	80	110
C	52.5	56.5	51.5	55.5	65.5
D1	15.5	15	8	9.5	12
D2	23.5	26.5	29	34	42
D3	13.5	15	14.5	12	12
E1	2.4	3	3	3.6	3.6
E2	14.1	16	17.5	18.7	23.4
E3	7	7.5	8.5	12	15
F	6	6.5	7.5	10	14
ΦG	48	60	70	88	114
ΦH	70	80	90	110	142
11	18.5	19.5	18.5	20	29
12	22	23.5	20.5	23	24
13	12	13.5	12.5	12.5	12.5
J1	2.5	2.5	/	/	/
J2	7	7	7	6.5	/
J3	7	7	7	6.5	7
K1	/	/	/	/	1.7
K2	/	/	/	/	12
ΦL1	23	29	34	43	50
ΦL2	20	25	30	40	45
ΦL3	20	25	30	38	45
ΦL4	14	19	21	29	36
ΦM1	22	28	34	43	50
ΦM2	20	25	30	38	45
ΦM3	/	/	/	/	42.5
ΦM4	14	19	21	29	36
ΦN1j6	20	25	30	38	45
ΦN2	14.5	19.5	21.5	29.5	36.5
O1	10	10	10	10	10
O2	22.5	24.5	19.5	22.5	30.5
O3	20	22	22	23	25
P1	3	3	6	6	6
P2	M3	M3	M3×6	M3×6	M3
Q1	8	12	12	12	12
Q2	3.5	3.5	3.5	4.5	5.5
ΦR	64	74	84	102	132
ΦS	/	/	25.5	33.5	40.5
ΦU	44	54	62	77	100
V1	8 part in 12 even distributions	16 part in 20 even distributions	16	16	16
V2	M3×5	M3×6	M3×6	M4×8	M5×10
V3	Φ3.5×6	Φ3.5×6.5	Φ3.5×7.5	Φ4.5×10	Φ5.5×14
Φα	36.5	45	54.5	64.5	86
b	1	1	1.7	1.5	2
Φc	31	38	48	58	77
d	1.2	1.7	1.7	1.9	2.1

- The size marked with \* symbol refers to the axial connection position and tolerance of three parts, which are wave generator, flexspline, circular spline. The size will have an influence on performance and intensity, therefore, please strictly abide by it.
- There is also difference in tolerance owing to different manufacturing method(casting and machining) for parts and components. For size without giving clear indication of tolerance, please contact with our company or authorized distributor if you needed more information.
- Owing to flexspline can be distorted, please use inwall size greater than φa.b.c and lesser than d in order to prevent it from being in touch with shell.
- Wave generator is individually packaged when delivering the product.



# LHD serie

LHD series' flexspline with flanging ultra short tube structure. Which can be used when circular spline fixed, and the flexspline as end output. It can also used to fix the flexspline, and the circular spline as end output. The axial length of LHD-I is shortened by 50%, LHD-III is shortened by 15%, without changing product performance.

## Application

- Industrial robot
- Humanoid robot
- Semiconductor manufacturing equipment
- FPD manufacturing equipment
- Space equipment

## Combinative structure of LHD series

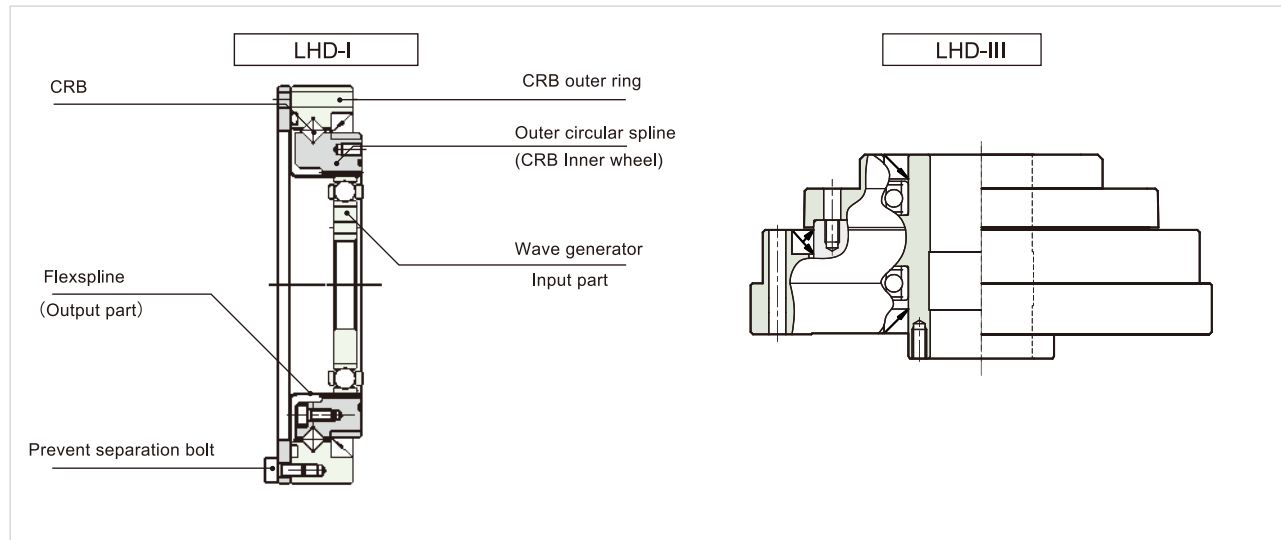

## LHD-I size chart

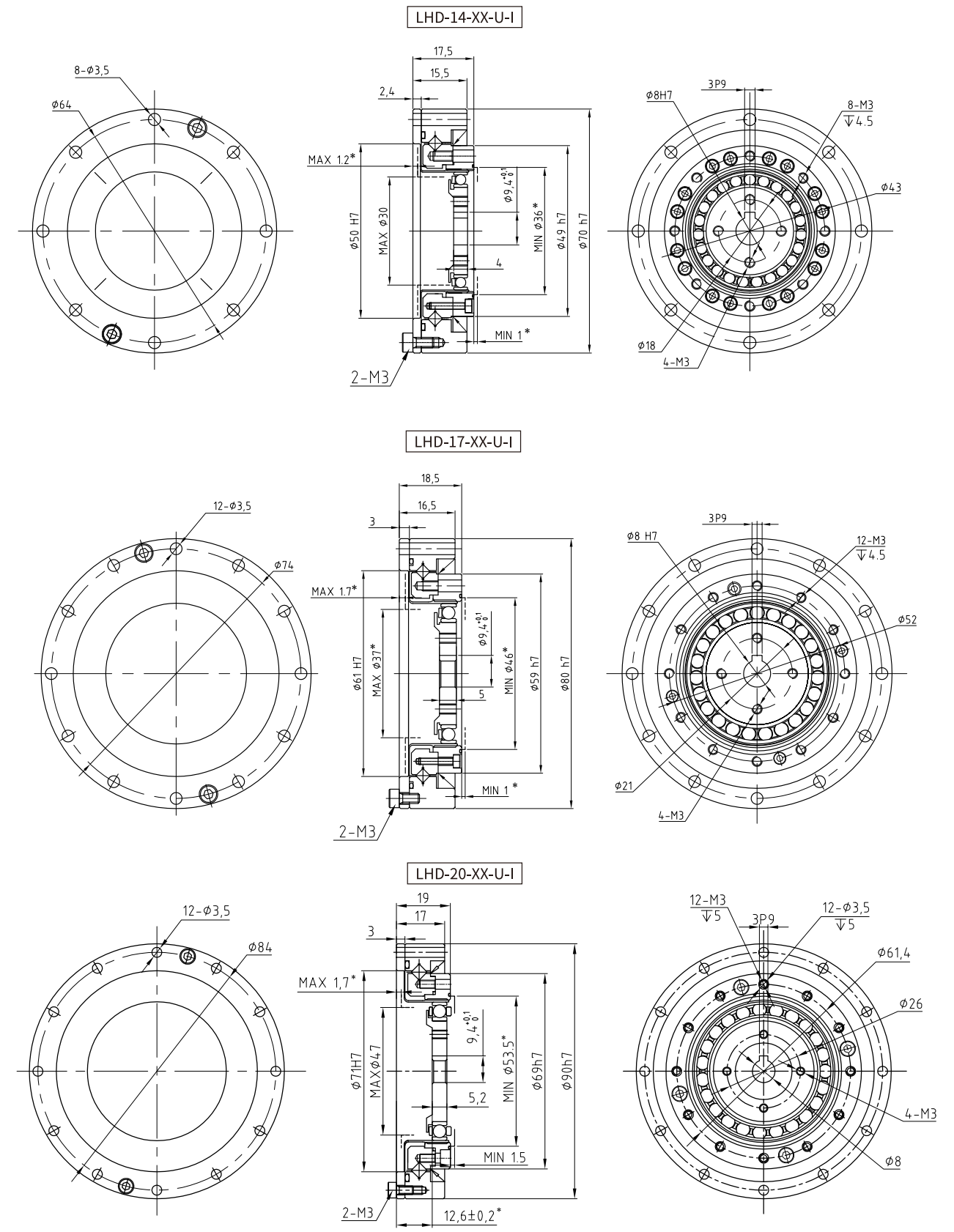

For detailed information of product, please confirm it with delivery specification figure.

## Rated parameter table of LHD series

Model	Reduction ratio	Rated torque at 2000r/min input	Permissible peak torque at start and stop	Permissible maximum value for average load torque	Permissible maximum momentary torque	Permissible maximum input rotational speed(Grease)	Permissible average input rotational speed(Grease)	Backlash	Desian life
		Nm	Nm	Nm	Nm	r/min	r/min		
14	50	3.7	12	4.8	23	8500	3500	≤20	9000
	80	5.1	15	6.2	29				
	100	5.4	19	7.7	35				
17	50	11	23	18	48	7300	3500	≤20	9000
	80	14	29	21	54				
	100	16	37	27	71				
20	50	17	39	24	69	6500	3500	≤20	9000
	80	23	49	28	78				
	100	28	57	34	95				
25	50	27	69	38	127	5600	3500	≤20	9000
	80	42	91	62	157				
	100	47	110	75	184				
32	50	53	151	75	268	4000	3000	≤20	9000
	80	79	202	126	350				
	100	96	233	151	420				

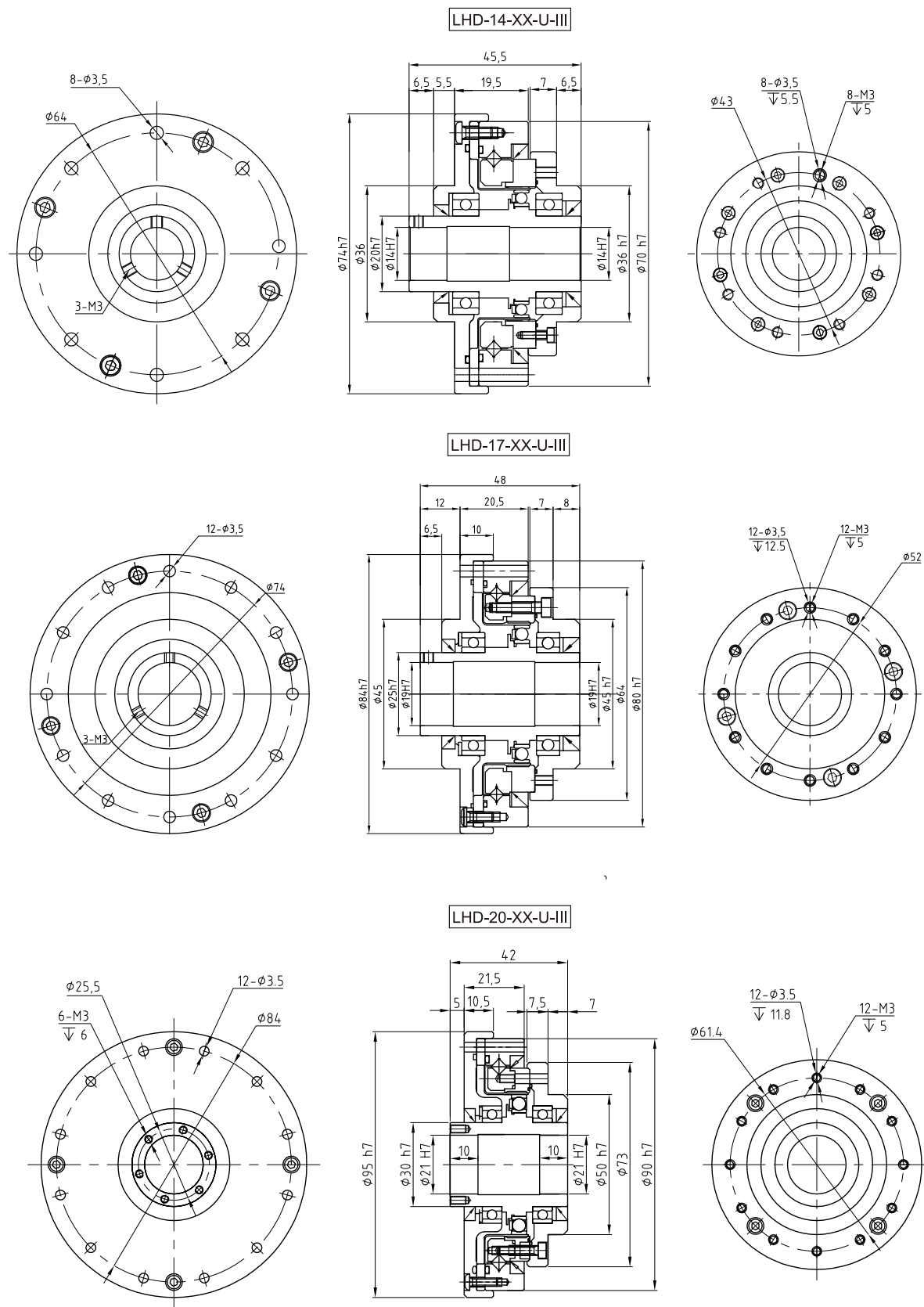

■ For detailed information of product, please confirm it with delivery specification figure.

# SERVICE

## Warranty

Regulations of warranty period and warranty scope of Laifual Drive as follows:

### Warranty period

Warranty period is the earlier time between one year after delivery or working time of 2,000 hours on condition that it is used in normal assembly state and lubrication condition recorded in product content.

### Warranty scope

Our company is responsible for maintenance or replacement of the product when malfunction resulting from manufacturing defect under warranty period. However, following situations are out of warranty scope.

- Damage results from unsuitable operation or illegal use by clients.
  - Damage results from modification or repair that is not carried out by our company.
  - Damage not caused by the product.
  - Damage results from natural disaster and the like but not the responsibility of our company.
- What's more, the warranty mentioned here is only for our product. Other loss caused by damage of the product and related man-hour and cost of assembly and disassembly of equipment is out of the scope of our company's responsibilities.



## Trademark

The following trademark has been registered in China.



## Application



Metal Working Machine



Processing Machines

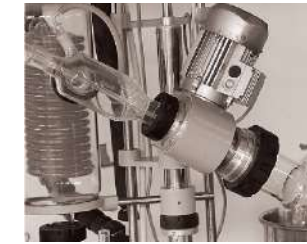

Measurement, Analytical and Test Systems



Medical Equipment

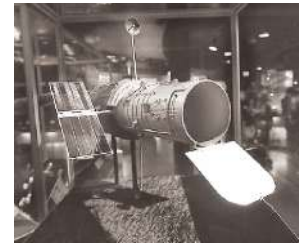

Telescopes



Energy

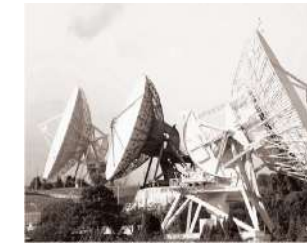

Communication Equipment



Crating and Packaging Machines



Space Equipment

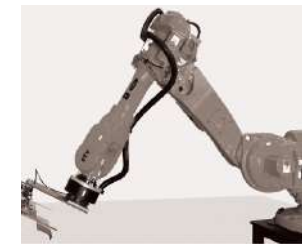

Robots



Humanoid Robots



Glass and Ceramic Manufacturing Systems



Printing, Bookbinding and Paper

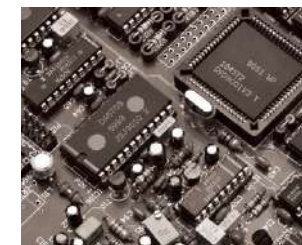

Printed Circuit Board Manufacturing Machines



Aircraft



Semiconductor Manufacturing Systems



Flat Panel Display Manufacturing Systems



Wood, Light Metal and Plastic Machine Tools



Paper-making Machines





Optical Machines

## Certification





 **Warning** Means that improper use or handling could result in a risk of death or serious injury.

 **Caution** Means that improper use or handling could result in personal injury or loss of property.

## Application restriction





This product cannot be used for the following applications:

- Space flight facility
- Aircraft equipment
- Nuclear power equipment
- Equipment and apparatus used in domestic homes
- Vacuum equipment
- Automotive equipment
- Personal recreation equipment
- Equipment that directly works on human bodies
- Equipment for transport of humans
- Equipment for use in a special environment





- Please consult with our authorized distributor in advance for applications mentioned above.
- Fail-safe devices that prevent an accident must be designed into the equipment when the products are used in any equipment that could result in personal injury or damage to property in the event of product failure.

## Design Precaution





Be certain to read the catalog when designing the equipment.

<p> <b>Use only in the proper environment</b></p> <p>Please ensure to comply with the following environmental conditions:</p> <ul style="list-style-type: none"> <li>• Ambient temperature 0–40°C.</li> <li>• No splashing of water or oil.</li> <li>• Do not expose to corrosive or explosive gas.</li> <li>• No dust such as metal powder.</li> </ul>	<p> <b>Install the equipment properly</b></p> <ul style="list-style-type: none"> <li>• Carry out the assembly and installation precisely as specified in the catalog.</li> <li>• Observe our recommended fastening methods (including bolts used and tightening torques). Improper assembly may cause problems such as vibration, reduction in life, deterioration of precision and product failure in operation.</li> </ul>
<p> <b>Install the equipment with the required precision</b></p> <ul style="list-style-type: none"> <li>• Please design and assemble parts correctly, to ensure the recommended installation accuracy in the catalog.</li> <li>• Failure to hold the recommended tolerances may cause problems such as vibration, reduction in life, deterioration of precision and product failure.</li> </ul>	<p> <b>Use the specified lubricant</b></p> <ul style="list-style-type: none"> <li>• Do not use the lubricant recommended by the company, can reduce the life of the product. Replace the lubricant as recommended.</li> <li>• The complete units are factory lubricated. Do not mix with other kinds of grease.</li> </ul>

Precautions for use: Be sure to read the catalog when operating

<p> <b>Please take the product and parts carefully</b></p> <ul style="list-style-type: none"> <li>• Please do not use a hammer etc to strike all parts and assembly units forcefully. In addition, please make sure fissure and scars won't be taken place because of falling down etc. Otherwise it will lead to damage.</li> <li>• The performance cannot be guaranteed when is used under the condition of damage. It might lead to failures like damage etc.</li> </ul>	<p> <b>Please do not exceed its allowable torque when used</b></p> <ul style="list-style-type: none"> <li>• Please do not exceed allowable maximum torque of first moment when exerting torque. Otherwise untight bolt, wobble and damage of buck-up part might be occurred, which will lead to malfunction.</li> <li>• If output shaft is directly linked to articulated arm etc, there's a chance that it might be damaged because of collision of articulated arm, which the output shaft cannot not be controlled.</li> </ul>
<p> <b>Please do not alter matching components</b></p> <ul style="list-style-type: none"> <li>• All components of the product is made out of processing a complete set. Specified properties cannot be guaranteed when using it with other sets.</li> </ul>	<p> <b>Please do not disassemble combo products</b></p> <ul style="list-style-type: none"> <li>• Disassembling and reassembling the combo product are strictly prohibited. Otherwise, there is no way to regain its original performance.</li> </ul>

Usage of lubricating grease

<p> <b>Installation notes</b></p> <ul style="list-style-type: none"> <li>• An inflammation may be caused if it splashes into eyes. Please wear protective glasses etc when operation in order to keep it from the eyes.</li> <li>• An inflammation may be caused if it touches the skin. Please wear protective gloves etc when operation in order to keep it from the skin.</li> <li>• Please do not devour (diarrhea and vomit etc will be caused)</li> <li>• Please note do not cut your finger when opening the container. Please wear protective gloves well.</li> <li>• Please keep it away from children.</li> </ul>	<p> <b>Emergency management</b></p> <ul style="list-style-type: none"> <li>• Once it splashes into eyes, please wash it for 15 minutes with clean water immediately and receive treatment.</li> <li>• Once it touches the skin, please use the water and soap to wash it fully.</li> <li>• Once it's being swallowed, please do not try hard vomiting but immediately receive the doctor's treatment.</li> </ul>
<p> <b>Treatment of waste oil and container</b></p> <ul style="list-style-type: none"> <li>• Regulations require the user is in duty bound to carry out treatment method. Please handle it properly according to relevant laws and regulations. When in doubt, please consult the authorized agent first, then handle it correctly.</li> <li>• Please do not exert pressure to an empty container. By doing this may cause it fracture.</li> <li>• Please do not weld, heat, trepan or trim to the container. Otherwise, it may burn up the residue inside.</li> </ul>	<p> <b>Storage methods</b></p> <ul style="list-style-type: none"> <li>• Please seal it tight after used, in order to prevent dusts and moisture etc from mixing in. Avoid direct sunlight.</li> <li>• As to products with long-term inventory, make sure performance and rust protection.</li> <li>• For surface treatment, please refer to the delivery figure.</li> </ul>

About scrapping

-  **Disposal should be carried out in accordance with the industrial waste standard .**
- Please process it in accordance with industrial waste when scrapping.